

ONE FOCUS



ANNUAL REPORT 2009

FINANCIAL HIGHLIGHTS

Year ended June 30 (dollars in thousands, except per share data)	2009	2008	2007	2006	2005
Operating Performance					
Sales	\$ 1,999,859	\$ 2,589,786	\$ 2,265,336	\$ 2,213,233	\$ 2,090,978
Restructuring and Asset Impairment Charges	173,656	39,891	5,970	—	4,707
(Loss) Income from Continuing Operations	(102,402)	163,666	174,717	267,652	107,968
Diluted Earnings per Share – Continuing Operations	(1.40)	2.10	2.22	3.38	1.42
Operating Cash Flow	192,263	279,786	199,006	19,053	202,327
Financial Condition					
Total Assets	\$ 2,346,974	\$ 2,784,349	\$ 2,606,227	\$ 2,435,272	\$ 2,092,337
Total Debt, including Capital Leases and Notes Payable	485,957	346,652	366,829	411,722	437,374
Total Shareowners' Equity	1,247,443	1,647,907	1,484,467	1,295,365	972,862
Total Debt to Total Equity	39.0%	21.0%	24.7%	31.8%	45.0%
Other Data					
Capital Expenditures	\$ 104,842	\$ 163,489	\$ 92,001	\$ 79,593	\$ 88,552
Research and Development	27,604	32,564	28,814	26,138	23,024
Number of Employees	11,600	13,700	14,000	13,300	14,000
Stock Information					
Market Price per Share – High	\$ 38.75	\$ 45.61	\$ 41.48	\$ 33.69	\$ 26.36
Market Price per Share – Low	12.82	26.00	24.85	22.33	20.17
Dividends per Share	0.48	0.47	0.41	0.38	0.34
Diluted Weighted Average Shares Outstanding	73,122	78,201	78,545	79,101	76,112
Number of Shareowners	2,425	2,462	2,748	3,158	2,997

Amounts have been restated to reflect discontinued operations.

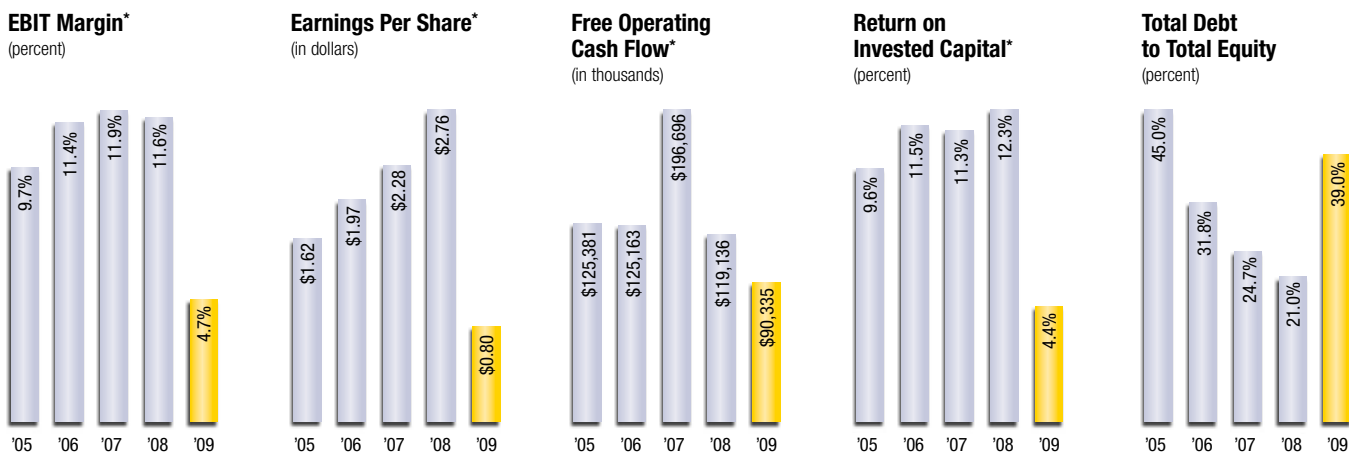

* On an adjusted basis

Forward-Looking Statements Certain statements in this report relate to future events and expectations and, as such, constitute forward-looking statements. Forward-looking statements may also include words such as “anticipates,” “believes,” “estimates,” “expects,” “hopes,” “targets,” “should,” “will,” “will likely result,” “forecast,” “outlook,” “projects,” or similar expressions. Forward-looking statements involve known and unknown risks, uncertainties, and other factors that may cause the actual results, performance, or achievements of Kennametal to be different from those expressed or implied in the forward-looking statements. For further discussion of forward-looking statements, including some of the specific factors that may cause such a difference, see the forward-looking statements and risk factors disclosure included in our 2009 Form 10-K. Kennametal disclaims any intention or obligation to update or revise any forward-looking statements. This document includes certain non-GAAP financial measures as defined by SEC rules. As required by Regulation G, we have provided a reconciliation of those measures to the most directly comparable GAAP measures, which is available in the section titled *2009 Supplemental Financial Data*.

TO OUR FELLOW SHAREOWNERS

During fiscal 2009, Kennametal's management team continued to implement our business strategies, while maintaining one focus: to achieve our long-range vision of the company's future. The fiscal year, however, presented extraordinary challenges that tested Kennametal and most companies around the world. An uncertain economic and political climate, the collapse of the financial markets and a deepening global recession impacted virtually every business sector, end market and geography. A rapid decline in customer demand resulted in an approximate 40 percent year-over-year decrease in sales for the second half of our fiscal year. These collective factors constrained our financial performance and created one of the weakest operating environments in Kennametal's 70-year history.

I am proud to say that we responded aggressively and effectively to these challenges. Drawing on our disciplined corporate culture, we saw the unfavorable market environment as an opportunity to build a better business—one that is leaner, more efficient and better equipped to deliver long-term performance when the recovery begins. As early as April 2008, we initiated a restructuring program aimed at reducing costs and improving efficiencies. In fiscal 2009, we expanded this program, and as conditions deteriorated, we proactively implemented a series of new measures. We launched a program that is expected to permanently remove \$125 million annually in fixed costs from our business, while also undertaking temporary cost-reduction measures. We streamlined our manufacturing footprint and began the process of closing seven facilities in North America and Europe. We made the hard decision to reduce global headcount by 15 percent. We continued to lower the number of SKUs in our product portfolio, ending the year with 117,000, compared with nearly 400,000 just five years ago. We continued to shape our portfolio, divesting our high-speed steel drills product lines and acquiring Tricon Metals & Services, which expands our ability to serve the surface and underground mining markets. We expanded the deployment of Lean principles in manufacturing and shared-services functions. In addition, we continued to implement strategic pricing actions to recover higher raw materials costs. These combined efforts helped us to offset a considerable portion of the impact of the sales decline, achieve a modest profit on an adjusted basis and generate healthy cash flow from operating activities of \$192 million for the fiscal year.

In early July 2009, we took measures to further enhance our liquidity, increased our financial flexibility and strengthened our balance sheet. We amended our \$500 million revolving bank credit facility and completed an equity offering that generated \$120 million—proceeds that we used to repay debt under the bank facility. These efforts will better prepare Kennametal to weather volatile market conditions, while positioning us to capitalize on a market upturn when it occurs.



Carlos M. Cardoso
*Chairman of the Board, President and
Chief Executive Officer
Shareowner*

Fiscal 2009 Achievements

Generated 43 percent of revenues from new products

Secured 37 new patents

Paved the way to capture \$125 million in permanent cost reductions annually

Reduced SKUs to 117,000 from nearly 400,000 five years ago

Generated \$192 million in operating cash flow

Shaped our portfolio through strategic acquisitions and divestitures



2009 Executive Management Council

LEFT TO RIGHT

John R. Tucker

Vice President and Chief Technical Officer

Steven R. Hanna

Vice President and Chief Information Officer

Paul J. DeMand

*Vice President and President,
Metalworking Solutions & Services Group*

Philip H. Wehl

*Vice President Kennametal Value Business
System (KVBS) and Lean Enterprise*

Frank P. Simpkins

Vice President and Chief Financial Officer

Carlos M. Cardoso

*Chairman of the Board, President and
Chief Executive Officer*

Kevin R. Walling

Vice President and Chief Human Resources Officer

David W. Greenfield

Vice President, Secretary and General Counsel

John H. Jacko, Jr.

Vice President and Chief Marketing Officer

Gary W. Weismann

*Vice President and President,
Advanced Materials Solutions Group*

In addition to these initiatives, we continued to focus on ways to drive long-term shareowner value. We executed our strategy of operating a global business that is well balanced in terms of products, businesses, end markets and geographies. We also maintained Kennametal's leadership in technology and innovation, one of our key competitive advantages, reflected in the fact that new products generated 43 percent of our fiscal 2009 sales. During the year, we continued to launch "best-in-class" new products, introducing new platforms for both the Metalworking Solutions and Services Group (MSSG) and the Advanced Materials Solutions Group (AMSG). We also continued to support the efforts of our scientists who help to ensure that Kennametal remains our customers' "best practice partner" by introducing products that increase their productivity and savings. Our success in delivering innovation is evidenced by the more than 1,700 patents we have been granted, including 37 in fiscal 2009 alone.

In summary, the challenges of fiscal 2009 severely tested Kennametal. Faced with extremely difficult conditions, we clearly demonstrated our stability and strengths. These include our core strategies and disciplined management operating system; our engaged Board, experienced management team, and exceptionally committed global workforce; and our well-balanced portfolio of businesses that serve increasingly diverse end markets and geographies. They also include our robust pipeline of innovative products, our strong customer relationships and our Lean-focused culture. These qualities sustained Kennametal during a demanding year and allowed us to emerge a stronger, leaner enterprise with a solid business foundation—a company that is well positioned to deliver improved results.

We recognize that there will be additional challenges in the months ahead. Though we believe that the downturn is close to its bottom, its magnitude leaves us cautious about predicting what is to come. However, based on certain early indicators, we are optimistic that our operating environment may moderately improve in the second half of fiscal 2010, particularly in countries that have strong economic stimulus programs in place. We also believe that the very nature of our consumables business positions us to benefit relatively early in the cycle and realize higher operating leverage in an industrial upturn.

In the meantime, we continue to manage Kennametal by maintaining our one focus on fulfilling our long-range vision of the company's future. This includes continuing to invest in our core business while balancing our portfolio and focusing on our fundamentals—efforts that we believe will enable us to deliver quality earnings and sustainable growth over the long term. Our commitment to shareowners remains constant: to achieve 15 percent EBIT margin and 14 to 15 percent ROIC. As we pursue these goals, we look forward to keeping you informed of our progress, and we thank you, as always, for your commitment to Kennametal and our vision.

Carlos M. Cardoso
*Chairman, President and Chief Executive Officer
Shareowner*

OUR BUSINESSES

MSSG

Metalworking Solutions and Services Group

MSSG is one of the world's largest providers of consumable metal-cutting tools and tooling systems, serving manufacturers in industries throughout the world. MSSG provides tailored solutions to its customers by engineering services aimed at improving their productivity and competitiveness. MSSG serves a variety of industries that cut and shape metal and composite parts, including manufacturers of automobiles, trucks, aerospace components, farm equipment, oil and gas drilling and processing equipment, railroad equipment, marine and power generation equipment, light and heavy machinery, appliances, factory equipment and metal components. It also serves job shops and maintenance operations.

MSSG Sales
(millions of dollars)

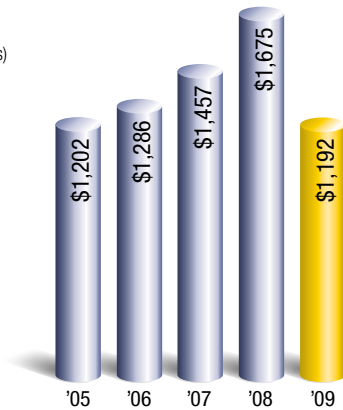

AMSG

Advanced Materials Solutions Group

AMSG produces and sells tungsten carbide products used in mining, highway construction and engineered applications that require exceptional wear and corrosion resistance. AMSG also manufactures and markets engineered components with a proprietary metal cladding technology, as well as other hard materials that provide wear resistance and life extension. In addition, it sells metallurgical powders to manufacturers of cemented tungsten carbide products and provides engineered component process technology and materials. AMSG is a global market leader in mining and highway construction tooling, as well as one of the largest independent suppliers of oil field compact bits in the world.

AMSG Sales
(millions of dollars)

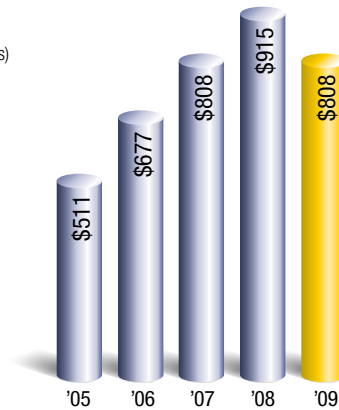

WHO IS KENNAMETAL?

Kennametal Inc. (NYSE:KMT) delivers productivity by providing innovative custom and standard wear-resistant solutions to customers seeking peak performance in demanding environments. Kennametal's proven productivity is enabled through its advanced materials sciences and application knowledge. Its commitment to a sustainable environment provides additional value to its customers. Companies operating in diverse industries—from airframes to coal mining, from engines to oil wells, from turbo chargers to construction—have recognized Kennametal for its extraordinary contributions to their value chains. In fiscal year 2009, customers bought approximately \$2 billion of Kennametal's products and services, delivered by nearly 12,000 talented employees in over 60 countries. More than 50 percent of these revenues were generated outside North America. For more information, please visit the company's website at www.kennametal.com.



OUR FEATURED END MARKETS



AEROSPACE AND DEFENSE

From lightweight composite materials to exotic alloys, Kennametal is committed to reducing risks and costs in the manufacture of aerospace and defense programs. We partner with our customers to implement high-performance tools and solutions with minimum cost-per-part and high repeatability as goals.

Workpiece/Material

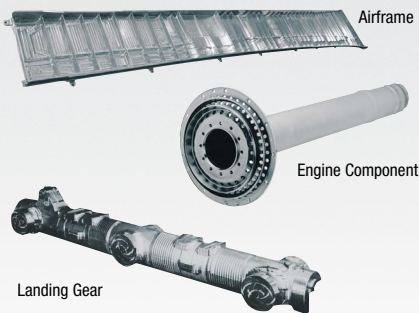

Our Solutions



ENERGY RESOURCES

From directional drilling and mud motor protection to surface preparation and abrasive blasting, Kennametal's experience and technologies assist synthetic diamond; oil, gas, and petrochemical; and power-generation customers to perform better, faster and more efficiently than ever before. We are helping to make the energy industry one of the most productive in the world.

Workpiece/Material

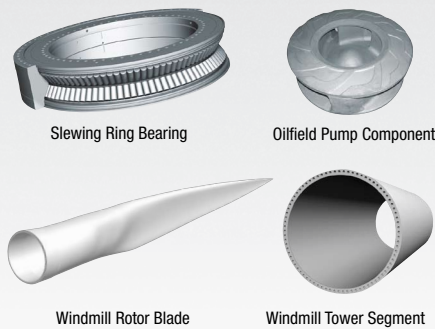

Our Solutions

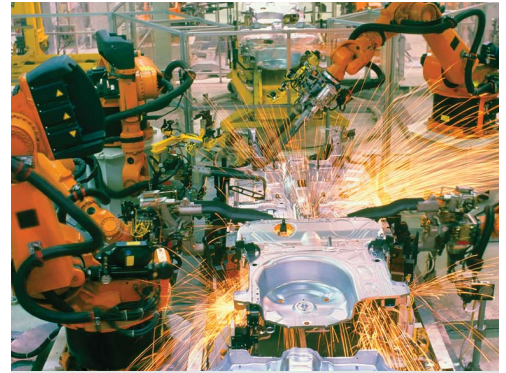

GENERAL INDUSTRY

Kennametal enables leading general industry manufacturers to compete globally. We provide a full range of engineered solutions, including custom products for carbide and advanced ceramics that offer exceptional resistance to wear, abrasion, corrosion and high temperatures, thereby lowering the rate of replacement and minimizing expensive downtime.

Workpiece/Material



Our Solutions



PROVIDING SOLUTIONS FOR:

- SHAPING
- WEAR RESISTANCE
- CORROSION RESISTANCE



MINING

Kennametal's surface and underground mining tools, accessories and wear-related products withstand the harshest environments. No matter what the mining application—from longwall shearing to the mining of gold, diamonds, iron ore and platinum—Kennametal has high-performance, long-lasting carbide tooling solutions to optimize productivity and keep our customers competitive and profitable.

Workpiece/Material



Coal

Our Solutions



ROAD REHABILITATION

Kennametal offers a wide range of grader blades, cutting tools and blocks to help customers tackle the most demanding road maintenance jobs. Whether they are engaged in road milling, road grading, snowplowing or soil stabilization, our goal is to use the best in engineering to deliver premium quality and performance to our customers.

Workpiece/Material



Road Surface

Our Solutions

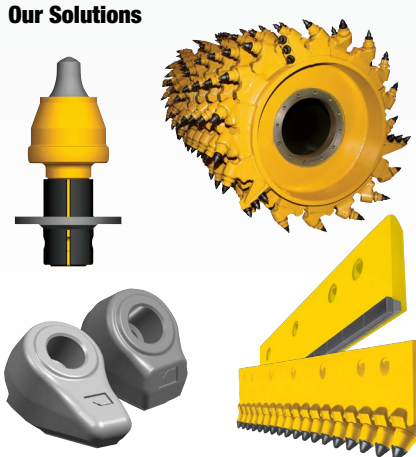

TRANSPORTATION

Kennametal is a transportation expert, pioneering innovative solutions with automotive, shipbuilding and railroad customers around the world that improve both cost and quality. In today's competitive world, no one can support our customers better, while delivering the continued service and quality that have become Kennametal trademarks.

Workpiece/Material



Engine Block and Components

Our Solutions



OUR ROADMAP FOR GROWTH

Total Sales
(millions of dollars)

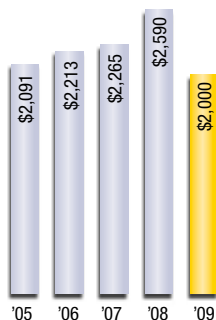

In fiscal 2009, Kennametal faced an operating environment that was characterized by a severe market downturn and unprecedented economic challenges. Due to careful planning and preparation, however, the company was able to enter this period from a position of strength, with strong metrics, a solid balance sheet and a Lean-focused corporate culture. This solid foundation, combined with an aggressive restructuring program and a steady focus on its management and operating strategies, positioned Kennametal to emerge from this period as a stronger enterprise. Kennametal executive leadership provides some perspective on the year and explains why the company is positioned to perform at higher levels once industry conditions improve.

Q: Kennametal's fiscal year 2009 financial results were substantially lower than they were a year ago. What did the company do to prepare for the economic downturn?

A: While few predicted the magnitude of the challenges that manufacturers would face in fiscal 2009, Kennametal did an effective job of anticipating the economic downturn—and focused on controlling those aspects of our business that we could. We started to restructure in April 2008, and when customer demand weakened, we initiated additional cost reduction measures that delivered \$50 million in restructuring benefits in fiscal 2009. We expect to save \$125 million annually from these restructuring actions once they are fully implemented. We streamlined our business by managing our portfolio in a way that significantly cut costs and will help drive long-term profitability. We implemented a strategic price realization program that has helped us to recover higher raw materials costs. We also put into place employee furloughs, suspended company 401K matches, and scaled back travel. In addition, we focused on receivables collections, lowered inventories to match business levels and minimized capital expenditures to preserve cash. These actions and others enabled us to generate healthy operating cash flow of \$192 million in fiscal 2009.

Operating Income*
(millions of dollars)

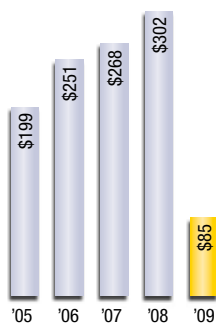

Q: Has Kennametal changed its strategy as a result of events in fiscal 2009?

A: No. Though we have refined certain tactics, our strategies remain the same. We continue to balance our business geographically, with a goal to generate revenues equally from North America, Western Europe and the rest of the world. We continue to grow the Advanced Materials Solutions Group so that it will ultimately represent 50 percent of sales. We continue to improve our customers' competitiveness and profitability by introducing new products at a market-leading pace. We continue to recruit and retain top talent, and we continue to optimize our channel branding strategies. We continue to operate under the disciplined approach of the Kennametal Value Business System.

Net Income*
(millions of dollars)

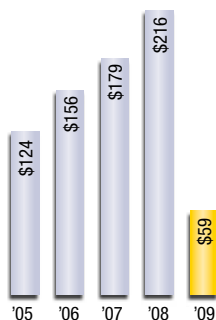

Q: What are your current priority uses of cash?

A: In the current environment, we are managing our business with a focus on maintaining our fundamentals and enhancing our liquidity. At the same time, we are preparing for growth. Our business is more streamlined and leaner than ever, and our simplified business model means that we can respond even more quickly to our customers' needs. We also continue to focus on delivering innovative products at a market-leading pace. We believe that these factors position us to return to healthy growth early in an economic upturn.

* On an adjusted basis, excluding special items

Q: How has Kennametal prepared itself for fiscal 2010?

A: We have worked hard to control as many aspects of our business as possible. We have invested carefully in our company's future with an emphasis on driving long-term profitability. In July, we also renegotiated our bank credit agreement and issued equity, using the proceeds to pay down debt. This comprehensive plan strengthened our financial flexibility and further enhanced our liquidity, which prepared us for continuing challenges while positioning us to benefit quickly when industry conditions turn around.

Q: What's the greatest challenge ahead for Kennametal?

A: We are intensely aware of the need to remain disciplined from a cost perspective as we emerge from the downturn. We have cut costs, and with a modest increase in sales volume, we should perform well from a margin perspective in an improved environment. This provides Kennametal with a host of opportunities—and the chance to return to profitability as quickly as possible. At the same time, we must remain flexible enough to invest where we need to and take full advantage of a turnaround. We are well positioned for a recovery, which we expect to see beginning in the second half of fiscal 2010. Our greatest challenge is to remain both disciplined and flexible on the cost side to accelerate our profitability.

Sales by Geographic Region

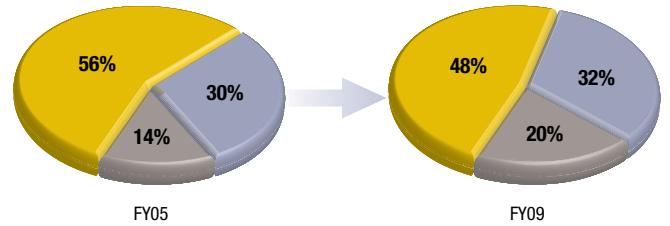

North America	56%	North America	48%
Western Europe	30%	Western Europe	32%
Rest of the World	14%	Rest of the World	20%

Sales by Business Unit

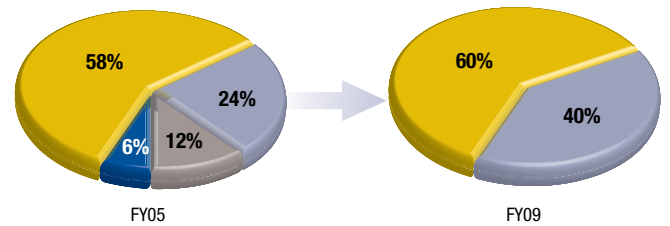

MSSG	58%	MSSG	60%
AMSSG	24%	AMSSG	40%
J&L	12%		
FSS	6%		

ASSET UTILIZATION

Primary Working Capital
(percent of sales)

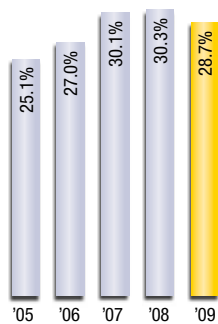

Capital Expenditures
(percent of sales)

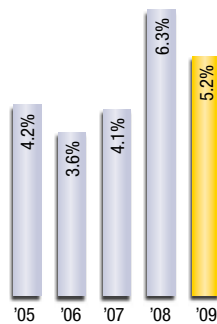

CASH GENERATION

Operating Cash Flow
(percent of sales)

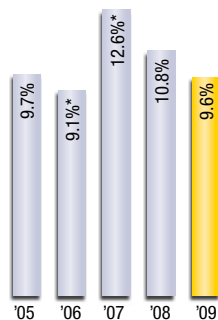

Effective Tax Rate*
(percent)

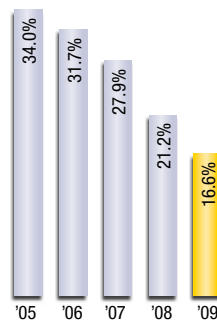

* Adjusted for one-time payments

* Excluding special items

Sales by End Market

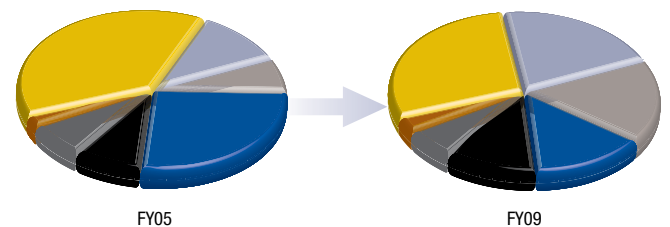

General Industry	38%	General Industry	29%
Mining & Construction	11%	Mining & Construction	20%
Other	7%	Other	17%
Vehicles	27%	Vehicles	14%
Energy	8%	Energy	11%
Aerospace	7%	Aerospace	6%
Machine Tool Builders	2%	Machine Tool Builders	3%

OUR COMMITMENT TO INNOVATION

Kennametal's focus on delivering innovative solutions to our customers has long been the company's hallmark. That commitment was even more important in fiscal 2009, when our customers around the globe faced unprecedented economic challenges. Kennametal entered the fiscal year with an intense mandate: to quickly adapt to our customers' needs, to deliver customized solutions, and to do so by targeting our resources to the world's fastest growing end markets.

At Kennametal, every solution we provide must meet our high standards for performance—each must improve our customers' manufacturing process and deliver productivity savings. The fact that our products deliver exceptional customer value enables us to maintain close ties with our customers and implement strategic pricing programs as appropriate. During fiscal 2009, our research scientists and development engineers worked to retain our status as a "best-practice" partner to our customers. We collaborated even more closely with them through the development process, securing the patents necessary to protect our intellectual property, introducing new products, maintaining a healthy product pipeline and eliminating SKUs as part of managing our products' life cycles. In fiscal 2009, our new products represented 43 percent of our total sales for the year.

Kennametal's high standards of innovation are recognized throughout our industry. Industry publications and market research surveys affirm

our commitment to be the best in customer satisfaction, and they consistently name Kennametal as leading the industry in terms of "most innovative" and "first in customer service." Third-party industry groups also praise Kennametal for our customer focus. In fiscal 2009, Frost & Sullivan recognized Kennametal with its Best-in-Class award for our new product development process, stating that our "persistent stance in nurturing a sustainable environment by developing eco-friendly and long-wearing products has placed the company beyond the reach of industry peers." The American Productivity and Quality Center (APQC), a leader in benchmarking, named Kennametal one of five best-practice partners in new product and service innovation, and recognized us for our world-class product development processes. Kennametal also received the Carnegie Science Center Honor for innovative excellence for the eighth time, which exemplifies the substantial commitment the company has made to maintain the highest industry standards for innovation and excellence.

Today, Kennametal remains more committed to our customers than ever. What's more, we are ideally equipped to serve them due to our outstanding product development process, the innovative nature of our product portfolio, and our ability to introduce products quickly to the marketplace. These factors, along with a management operating system that strongly supports research and development, differentiate Kennametal and position us for growth in the future.

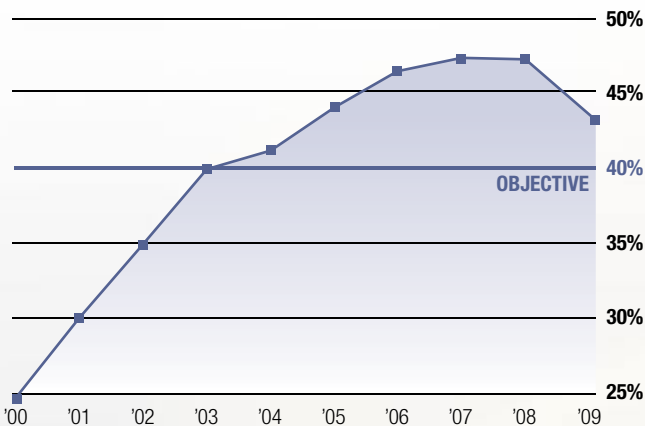

New Products as Percent of Sales (percent)

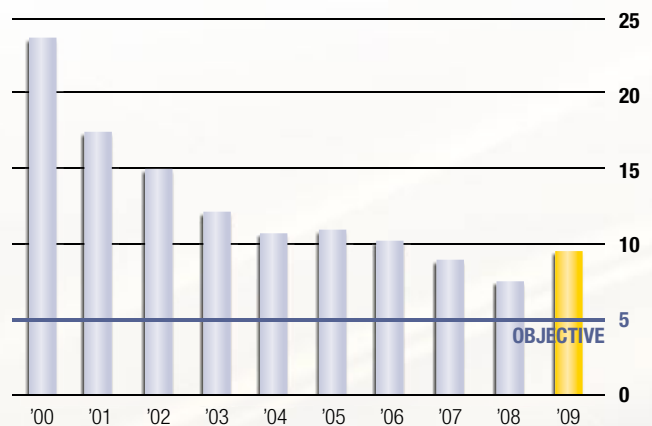

New Product Development Cycle Time (months)

2009 FORM 10-K

**UNITED STATES
SECURITIES AND EXCHANGE COMMISSION**
Washington, D.C. 20549

FORM 10-K

ANNUAL REPORT PURSUANT TO SECTION 13 OR 15(d) OF THE
SECURITIES EXCHANGE ACT OF 1934

FOR THE FISCAL YEAR ENDED JUNE 30, 2009

Commission File Number 1-5318

KENNAMETAL INC.
(Exact name of registrant as specified in its charter)

Pennsylvania **25-0900168**
(State or other jurisdiction of incorporation or organization) (I.R.S. Employer Identification No.)

World Headquarters
1600 Technology Way
P.O. Box 231
Latrobe, Pennsylvania **15650-0231**
(Address of Principal Executive Offices) (Zip Code)

Registrant's telephone number, including area code: **(724) 539-5000**

Securities registered pursuant to Section 12(b) of the Act:

Title of each class	Name of each exchange on which registered
Capital Stock, par value \$1.25 per share	New York Stock Exchange
Preferred Stock Purchase Rights	New York Stock Exchange

Securities registered pursuant to Section 12(g) of the Act: **None.**

Indicate by check mark if the registrant is a well-known seasoned issuer, as defined in Rule 405 of the Securities Act. Yes No

Indicate by check mark if the registrant is not required to file reports pursuant to Section 13 or Section 15(d) of the Act. Yes No

Indicate by check mark whether the registrant (1) has filed all reports required to be filed by Section 13 or 15(d) of the Securities Exchange Act of 1934 during the preceding 12 months (or for such shorter period that the registrant was required to file such reports), and (2) has been subject to such filing requirements for the past 90 days. Yes No

Indicate by check mark whether the registrant has submitted electronically and posted on its corporate Web site, if any, every Interactive Data File required to be submitted and posted pursuant to Rule 405 of Regulation S-T during the preceding 12 months (or for such shorter period that the registrant was required to submit and post such files). YES NO

Indicate by check mark if disclosure of delinquent filers pursuant to Item 405 of Regulation S-K is not contained herein, and will not be contained, to the best of registrant's knowledge, in definitive proxy or information statements incorporated by reference in Part III of this Form 10-K or any amendment to this Form 10-K.

Indicate by check mark whether the registrant is a large accelerated filer, an accelerated filer, a non-accelerated filer, or a smaller reporting company. See the definitions of "large accelerated filer," "accelerated filer" and "smaller reporting company" in Rule 12b-2 of the Exchange Act. Large accelerated filer Accelerated filer

Non-accelerated filer (Do not check if smaller reporting company) Smaller reporting company

Indicate by check mark whether the registrant is a shell company (as defined by Rule 12b-2 of the Exchange Act). Yes No

As of December 31, 2008, the aggregate market value of the registrant's Capital Stock held by non-affiliates of the registrant, estimated solely for the purposes of this Form 10-K, was approximately \$1,483,100,000. For purposes of the foregoing calculation only, all directors and executive officers of the registrant and each person who may be deemed to own beneficially more than 5% of the registrant's Capital Stock have been deemed affiliates.

As of July 31, 2009, there were 81,291,520 shares of the Registrant's Capital Stock outstanding.

DOCUMENTS INCORPORATED BY REFERENCE

Portions of the Proxy Statement for the 2009 Annual Meeting of Shareowners are incorporated by reference into Part III.

Table of Contents

Item No.	Page
PART I	
1. Business	1
1A. Risk Factors	5
1B. Unresolved Staff Comments	7
2. Properties	8
3. Legal Proceedings	9
4. Submission of Matters to a Vote of Security Holders	9
PART II	
5. Market for the Registrant's Common Equity, Related Shareowner Matters and Issuer Purchases of Equity Securities	10
6. Selected Financial Data	12
7. Management's Discussion and Analysis of Financial Condition and Results of Operation	13
7A. Quantitative and Qualitative Disclosures About Market Risk	26
8. Financial Statements and Supplementary Data	28
9. Changes in and Disagreements With Accountants on Accounting and Financial Disclosure	64
9A. Controls and Procedures	64
9B. Other Information	64
PART III	
10. Directors, Executive Officers and Corporate Governance	65
11. Executive Compensation	66
12. Security Ownership of Certain Beneficial Owners and Management and Related Shareowner Matters	66
13. Certain Relationships and Related Transactions, and Director Independence	66
14. Principal Accountant Fees and Services	66
PART IV	
15. Exhibits, Financial Statement Schedules	67
SIGNATURES	70

FORWARD-LOOKING INFORMATION

This Annual Report on Form 10-K contains “forward-looking” statements within the meaning of Section 27A of the Securities Act of 1933 and Section 21E of the Securities Exchange Act of 1934. Forward-looking statements are statements that do not relate strictly to historical or current facts. You can identify forward-looking statements by the fact they use words such as “should,” “anticipate,” “estimate,” “approximate,” “expect,” “may,” “will,” “project,” “intend,” “plan,” “believe” and other words of similar meaning and expression in connection with any discussion of future operating or financial performance or events. Forward-looking statements in this Form 10-K may concern, among other things, Kennametal’s expectations regarding our strategy, goals, plans and projections regarding our financial position, liquidity and capital resources, results of operations, market position, and product development, all of which are based on current expectations that involve inherent risks and uncertainties. Among the factors that could cause the actual results to differ materially from those indicated in the forward-looking statements are risks and uncertainties related to: the recent downturn in our industry; deepening or prolonged economic recession; restructuring and related actions (including associated costs and anticipated benefits); changes in our debt ratings; compliance with our debt arrangements; our foreign operations and international markets, such as currency exchange rates, different regulatory environments, trade barriers, exchange controls, and social and political instability; changes in the regulatory environment in which we operate, including environmental, health and safety regulations; our ability to protect and defend our intellectual property; competition; our ability to retain our management and employees; demands on management resources; availability and cost of the raw materials we use to manufacture our products; global or regional catastrophic events, including terrorist attacks or acts of war; integrating acquisitions and achieving the expected savings and synergies; business divestitures; potential claims relating to our products; energy costs; commodity prices; labor relations; demand for and market acceptance of new and existing products; and implementation of environmental remediation matters. Should one or more of these risks or uncertainties materialize, or should the assumptions underlying the forward-looking statements prove incorrect, actual outcomes could vary materially from those indicated. We provide additional information about many of the specific risks we face in the “Risk Factors” Section of this Annual Report on Form 10-K. We can give no assurance that any goal or plan set forth in forward-looking statements can be achieved and readers are cautioned not to place undue reliance on such statements, which speak only as of the date made. We undertake no obligation to release publicly any revisions to forward-looking statements as a result of future events or developments.

PART I

ITEM 1 – BUSINESS

OVERVIEW Kennametal Inc. was incorporated in Pennsylvania in 1943. We are a leading global supplier of tooling, engineered components and advanced materials consumed in production processes. We believe that our reputation for manufacturing excellence as well as our technological expertise and innovation in our principal products has helped us to achieve a leading market presence in our primary markets. End users of our products include metalworking manufacturers and suppliers across a diverse array of industries including the aerospace, automotive, machine tool, light machinery and heavy machinery industries, as well as manufacturers, producers and suppliers in a number of other industries including coal mining, highway construction, quarrying, and oil and gas exploration and production industries. Our end users' products include items ranging from airframes to coal, engines to oil wells and turbochargers to motorcycle parts.

We specialize in developing and manufacturing metalworking tools and wear-resistant parts using a specialized type of powder metallurgy. Our metalworking tools are made of cemented tungsten carbides, ceramics, cermets and other hard materials. We also manufacture and market a complete line of toolholders, toolholding systems and rotary cutting tools by machining and fabricating steel bars and other metal alloys. We are one of the largest suppliers of metalworking consumables and related products in the United States (U.S.) and Europe. We also manufacture products made from tungsten carbide or other hard materials that are used in engineered applications, mining and highway construction and other similar applications, including compacts and metallurgical powders. Additionally, we manufacture and market engineered components with a proprietary metal cladding technology and provide our customers with engineered component process technology and materials that focus on component deburring, polishing and producing controlled radii.

Unless otherwise specified, any reference to a "year" is to a fiscal year ended June 30.

BUSINESS SEGMENT REVIEW We operate in two business segments consisting of Metalworking Solutions & Services Group (MSSG) and Advanced Materials Solutions Group (AMSG). Segment determination is based upon internal organizational structure, the manner in which we organize segments for making operating decisions and assessing performance, the availability of separate financial results and materiality considerations. Sales and operating income by segment are presented in Management's Discussion and Analysis set forth in Item 7 of this annual report on Form 10-K (MD&A) and Note 23 in our consolidated financial statements set forth in Item 8 (Note 23).

METALWORKING SOLUTIONS & SERVICES GROUP In the MSSG segment, we provide consumable metalcutting tools and tooling systems to manufacturing companies in a wide range of industries throughout the world. Metalcutting operations include turning, boring, threading, grooving, milling and drilling. Our tooling systems consist of a steel toolholder and cutting tool such as an indexable insert or drill made from cemented tungsten carbides, ceramics, cermets or other hard materials. During a metalworking operation, the toolholder is positioned in a machine that provides turning power. While the workpiece or toolholder is rapidly rotating, the cutting tool insert or drill contacts the workpiece and cuts or shapes the workpiece. The cutting tool insert or drill is consumed during use and must be replaced periodically.

We also provide custom solutions to our customers' metalcutting needs through engineering services aimed at improving their competitiveness. Engineering services include field sales engineers identifying products that enhance productivity and engineering product designs to meet customer needs.

We serve a wide variety of industries that cut and shape metal and composite parts, including manufacturers of automobiles, trucks, aerospace components, farm equipment, oil and gas drilling and processing equipment, railroad, marine and power generation equipment, light and heavy machinery, appliances, factory equipment and metal components, as well as job shops and maintenance operations. We deliver our products to customers through a direct field sales force, distribution, integrated supply programs and electronic commerce. With a global marketing organization and operations worldwide, we believe we are one of the largest global providers of consumable metalcutting tools and supplies.

ADVANCED MATERIALS SOLUTIONS GROUP In the AMSEG segment, the principal business lines include the production and sale of cemented tungsten carbide products used in mining, highway construction and engineered applications requiring wear and corrosion resistance, including compacts and other similar applications. These products have technical commonality to our metalworking products. Additionally, we manufacture and market engineered components with a proprietary metal cladding technology as well as other hard materials that likewise provide wear resistance and life extension. These products include radial bearings used for directional drilling for oil and gas, extruder barrels used by plastics manufacturers and food processors and numerous other engineered components to service a wide variety of industrial markets. We also sell metallurgical powders to manufacturers of cemented tungsten carbide products, intermetallic composite ceramic powders and parts used in the metalized film industry, and we provide application-specific component design services and on-site application support services. Lastly, we provide our customers with engineered component process technology and materials, which focus on component deburring, polishing and producing controlled radii.

Our mining and construction tools include products fabricated from steel parts that are tipped with cemented carbide as well as wear resistant products made from proprietary steels and other hard materials. Mining tools, used primarily in the coal industry, include longwall shearer and continuous miner drums, blocks, conical bits, drills, pinning rods, augers, cladded products, wear pins and a wide range of mining tool accessories. Highway construction cutting tools include carbide-tipped bits for ditching, trenching and road planing, grader blades for site preparation and routine roadbed control and snowplow blades and shoes for winter road plowing. We produce these products for mine operators and suppliers, highway construction companies, municipal governments and manufacturers of mining equipment. We believe we are the worldwide market leader in mining and highway construction tooling.

Our customers use engineered products in manufacturing or other operations where extremes of abrasion, corrosion or impact require combinations of hardness or other toughness afforded by cemented tungsten carbides, ceramics or other hard materials. We believe we are the largest independent supplier of oil field compacts in the world. Compacts are the cutting edge of oil well drilling bits, which are commonly referred to as "rock bits." We sell these products through a direct field sales force, distribution and electronic commerce.

INTERNATIONAL OPERATIONS During 2009, 54.6 percent of our sales were generated in markets outside of the U.S. Our principal international operations are conducted in Western Europe, Asia Pacific, India, Canada and Latin America. In addition, we have manufacturing and distribution operations in Israel and South Africa, as well as sales companies, sales agents and distributors in Eastern Europe and other areas of the world. The diversification of our overall operations tends to minimize the impact of changes in demand in any one particular geographic area on total sales and earnings. Our international operations are subject to the risks of doing business in those countries, including foreign currency exchange rate fluctuations and changes in social, political and economic environments.

Our international assets and sales are presented in Note 23. Information pertaining to the effects of foreign currency exchange rate risk is presented in Quantitative and Qualitative Disclosures About Market Risk as set forth in Item 7A of this annual report on Form 10-K.

GENERAL DEVELOPMENT OF BUSINESS Over the past several years, we have been actively engaged in further balancing our geographic footprint between North America, Western Europe, and the rest of the world markets. This strategy, together with steps to enhance the balance of our sales among our end markets and business units, have helped to create a more diverse business base and thereby provide additional sales opportunities as well as limit reliance on and exposure to any specific region or market sector.

We entered fiscal year 2009 after delivering record sales in our fiscal year ended June 30, 2008. Our sales continued to grow during the first months of fiscal year 2009 and we reported record September quarter sales for the three months ended September 30, 2008. Following that, global economic conditions and industrial activity deteriorated substantially with a further downward acceleration in the March 2009 quarter. This resulted in significantly lower industrial production and much lower demand for our products in all major geographic regions as well as most industry and market sectors. This had a corresponding effect on our sales levels, operating performance and financial results.

In response to the impact of the rapid and steep decline in global demand, we have undertaken and will continue to aggressively implement restructuring and other actions to reduce our manufacturing costs and operating expenses. We also have taken, and will continue to take, other specific and targeted steps to maximize cash flow and liquidity. We remain confident in our ability to manage through the global economic downturn and are poised to respond quickly to further changes in global markets while continuing to serve our customers and preserve our competitive strengths. At the same time, we will maintain a sharp focus on cash flow. Further discussion and analysis of the development in our business is set forth in MD&A in Item 7 of this annual report on Form 10-K.

ACQUISITIONS AND DIVESTITURES On October 1, 2008, we acquired Tricon Metals and Services Inc. (Tricon) in our AMMSG segment for a net purchase price of \$64.1 million. Tricon is a leading supplier of custom wear solutions specializing in consumable proprietary steels for the surface and underground mining markets, including hard rock and coal. We also made a small acquisition within our MSSG segment in 2009.

On June 30, 2009, we completed the sale of our high speed steel drills business and related product lines (HSS) as we continued to focus on shaping our business portfolio and rationalizing our manufacturing footprint. Total cash proceeds from this divestiture, which was part of the MSSG segment, amounted to \$29.0 million. The pre-tax loss on the sale and related pre-tax charges of \$25.5 million, as well as the related tax effects, were recorded in discontinued operations in the June 2009 quarter. We expect to incur additional pre-tax charges related to this divestiture of \$4.0 million to \$7.0 million during the six months ending December 2009.

We continue to evaluate new opportunities for the expansion of existing product lines into new market areas where appropriate. We also continue to evaluate opportunities for the introduction of new and/or complementary product offerings into new and/or existing market areas where appropriate. Going forward, we expect to evaluate potential acquisition candidates that offer strategic technologies in an effort to continue to grow our AMMSG business and further enhance our MSSG market position.

MARKETING AND DISTRIBUTION We sell our products through the following distinct sales channels: (i) a direct sales force; (ii) a network of independent distributors and sales agents in North America, Europe, Latin America, Asia Pacific and other markets around the world; (iii) integrated supply and (iv) the Internet. Service engineers and technicians directly assist customers with product design, selection and application.

We market our products under various trademarks and trade names, such as Kennametal ®, the letter K with other identifying letters and/or numbers, Block Style K, Kenloc ®, Kenna-LOK™, KM Micro ®, Kentip ®, Widia Heinlein ®, Top Notch ®, ToolBoss ®, Kyon ®, Fix-Perfect ®, Mill1™, RTW ®, Circle ®, Conforma Clad ®, Extrude Hone ® and Surftran ®. Kennametal Inc. or a subsidiary of Kennametal Inc. owns these trademarks and trade names. We also sell products to customers who resell such products under the customers' names or private labels.

RAW MATERIALS AND SUPPLIES Major metallurgical raw materials consist of ore concentrates, compounds and secondary materials containing tungsten, tantalum, titanium, niobium and cobalt. Although an adequate supply of these raw materials currently exists, our major sources for raw materials are located abroad and prices fluctuate at times. We have entered into extended raw material supply agreements and will implement product price increases as deemed necessary to mitigate rising costs. For these reasons, we exercise great care in selecting, purchasing and managing availability of raw materials. We also purchase steel bars and forgings for making toolholders and other tool parts, as well as for producing rotary cutting tools and accessories. We obtain products purchased for use in manufacturing processes and for resale from thousands of suppliers located in the U.S. and abroad.

RESEARCH AND DEVELOPMENT Our product development efforts focus on providing solutions to our customers' manufacturing problems and productivity requirements. Our product development program provides discipline and focus for the product development process by establishing "gateways," or sequential tests, during the development process to remove inefficiencies and accelerate improvements. This program speeds and streamlines development into a series of actions and decision points, combining efforts and resources to produce new and enhanced products faster. This program is designed to assure a strong link between customer needs and corporate strategy and to enable us to gain full benefit from our investment in new product development.

Research and development expenses included in operating expense totaled \$27.6 million, \$32.6 million and \$28.8 million in 2009, 2008 and 2007, respectively. We hold a number of patents which, in the aggregate, are material to the operation of our businesses.

SEASONALITY Our business is not materially affected by seasonal variations. However, to varying degrees, traditional summer vacation shutdowns of metalworking customers' plants and holiday shutdowns often affect our sales levels during the first and second quarters of our fiscal year.

BACKLOG Our backlog of orders generally is not significant to our operations.

COMPETITION We are one of the world's leading producers of cemented carbide products and we maintain a strong competitive position in all major markets worldwide. We actively compete in the sale of all our products with approximately 40 companies engaged in the cemented tungsten carbide business in the U.S. and many more outside the U.S. Several of our competitors are divisions of larger corporations. In addition, several hundred fabricators and toolmakers, many of which operate out of relatively small shops, produce tools similar to ours and buy the cemented tungsten carbide components for such tools from cemented tungsten carbide producers, including us. Major competition exists from both U.S. - and internationally-based concerns. In addition, we compete with thousands of industrial supply distributors.

The principal elements of competition in our businesses are service, product innovation and performance, quality, availability and price. We believe that our competitive strength derives from our customer service capabilities, including multiple distribution channels, our global presence, state-of-the-art manufacturing capabilities, ability to develop solutions to address customer needs through new and improved tools and the consistent high quality of our products. With these strengths, we are able to sell products based on the value added productivity to the customer rather than strictly on competitive prices.

REGULATION We are not currently a party to any material legal proceedings; however, we are periodically subject to legal proceedings and claims that arise in the ordinary course of our business. While management currently believes the amount of ultimate liability, if any, with respect to these actions will not materially affect our financial position, results of operations or liquidity, the ultimate outcome of any litigation is uncertain. Were an unfavorable outcome to occur, or if protracted litigation were to ensue, the impact could be material to us.

Compliance with government laws and regulations pertaining to the discharge of materials or pollutants into the environment or otherwise relating to the protection of the environment did not have a material effect on our capital expenditures or competitive position for the years covered by this report, nor is such compliance expected to have a material effect in the future.

We are involved as a potentially responsible party (PRP) at various sites designated by the United States Environmental Protection Agency (USEPA) as Superfund sites. For certain of these sites, we have evaluated the claims and potential liabilities and have determined that neither are material, individually or in the aggregate. For certain other sites, proceedings are in the very early stages and have not yet progressed to a point where it is possible to estimate the ultimate cost of remediation, the timing and extent of remedial action that may be required by governmental authorities or the amount of our liability alone or in relation to that of any other PRPs. With respect to the Li Tungsten Superfund site in Glen Cove, New York, we remitted \$0.9 million in 2008 to the Department of Justice (DOJ) as payment in full settlement for its claim against us for costs related to that site.

Reserves for other potential environmental issues at June 30, 2009 and 2008 were \$5.3 million and \$6.2 million, respectively. The reserves that we have established for environmental liabilities represent our best current estimate of the costs of addressing all identified environmental situations, based on our review of currently available evidence, and take into consideration our prior experience in remediation and that of other companies, as well as public information released by the USEPA, other governmental agencies, and by the PRP groups in which we are participating. Although the reserves currently appear to be sufficient to cover these environmental liabilities, there are uncertainties associated with environmental liabilities, and we can give no assurance that our estimate of any environmental liability will not increase or decrease in the future. The reserved and unreserved liabilities for all environmental concerns could change substantially due to factors such as the nature and extent of contamination, changes in remedial requirements, technological changes, discovery of new information, the financial strength of other PRPs, the identification of new PRPs and the involvement of and direction taken by the government on these matters.

We maintain a Corporate Environmental, Health and Safety (EHS) Department, as well as an EHS Steering Committee, to monitor compliance with environmental regulations and to oversee remediation activities. In addition, we have established an EHS coordinator at our global manufacturing facilities. Our financial management team periodically meets with members of the Corporate EHS Department and the Corporate Legal Department to review and evaluate the status of environmental projects and contingencies. On a quarterly basis, we review financial provisions and reserves for environmental contingencies and adjust these reserves when appropriate.

EMPLOYEES We employed approximately 11,600 persons at June 30, 2009, of which approximately 4,900 were located in the U.S. and 6,700 in other parts of the world, principally Europe, India and Asia. At June 30, 2009, approximately 2,100 of the above employees were represented by labor unions. We consider our labor relations to be generally good.

AVAILABLE INFORMATION Our Internet address is www.kennametal.com. On our Investor Relations page on our Web site, we post the following filings as soon as reasonably practicable after they are electronically filed with or furnished to the Securities and Exchange Commission (SEC): our annual report on Form 10-K, our quarterly reports on Form 10-Q, our current reports on Form 8-K and any amendments to those reports filed or furnished pursuant to Section 13(a) or 15(d) of the Securities Exchange Act of 1934, as amended (Exchange Act). Our Investor Relations Web page also includes Forms 3, 4 and 5 filed pursuant to Section 16(a) of the Securities Exchange Act of 1934. All filings posted on our Investor Relations Web page are available to be viewed on this page free of charge. On the Corporate Governance page on our Web site, we post the following charters and guidelines: Audit Committee Charter, Compensation Committee Charter, Nominating/Corporate Governance Committee Charter, Kennametal Inc. Corporate Governance Guidelines, Code of Business Ethics and Conduct and Stock Ownership Guidelines. All charters and guidelines posted on our Corporate Governance Web page are available to be viewed on this page free of charge. Information contained on our Web site is not part of this annual report on Form 10-K or our other filings with the SEC. We assume no obligation to update or revise any forward-looking statements in this annual report on Form 10-K, whether as a result of new information, future events or otherwise. Copies of this annual report on Form 10-K and those items disclosed on our Corporate Governance Web page are available without charge upon written request to: Investor Relations, Quynh McGuire, Kennametal Inc., 1600 Technology Way, P.O. Box 231, Latrobe, Pennsylvania, 15650-0231.

ITEM 1A – RISK FACTORS

Downturns in the business cycle could adversely affect our sales and profitability. Our business has historically been cyclical and subject to significant impact from economic downturns. During 2009, economic conditions deteriorated substantially in many of the countries and regions where we do business and may remain depressed for the foreseeable future. This has had a commensurate effect on our sales and profitability, and we have responded by implementing restructuring and other actions to reduce our manufacturing costs and operating expenses. In light of the magnitude of the global economic downturn, we have limited visibility regarding global industrial activity and the corresponding demand for our products. We expect to continue to experience the adverse effects of the global recession for at least the next several months. We cannot assure you that our markets will recover in the foreseeable future. We cannot assure you that we will not incur additional restructuring charges, that we will achieve all of the anticipated benefits from restructuring actions we have taken or that our markets will recover in the near term.

Changes in the credit ratings assigned to our debt may adversely affect our ability to obtain capital and liquidity. In the fourth quarter both Standard & Poor's and Moody's have reaffirmed our current investment grade ratings, but have modified their outlook from stable to negative, reflecting global economic uncertainty. We also have an investment grade rating from Fitch with a negative outlook. If we experience multiple downgrades in our credit ratings or if the credit and capital markets were to deteriorate, our access to the capital markets, the price we would have to pay or the amount we could raise may be negatively impacted.

We rely on our revolving credit facility to provide additional liquidity and operating flexibility. Although we believe that the banks participating in our recently amended credit facility have adequate capital and resources, we can provide no assurance that all of these banks will continue to operate as a going concern in the future. If any of the banks in our lending group were to fail, it is possible that the borrowing capacity under our credit facility would be reduced. In the event that the availability under our credit facility was reduced significantly, we could be required to obtain capital from alternate sources in order to finance our capital needs. If it becomes necessary to access additional capital, it is possible that any such alternatives in the current market would be on terms less favorable than under our current credit facility, which could have a negative impact on our consolidated financial position, results of operations, or cash flows.

Our international operations pose certain risks that may adversely impact sales and earnings. We have manufacturing operations and assets located outside of the U.S., including Brazil, Canada, China, Europe, India, Israel and South Africa. We also sell our products to customers and distributors located outside of the U.S. During the year ended June 30, 2009, 54.6 percent of our consolidated sales were derived from non-U.S. markets. A key part of our long-term strategy is to increase our manufacturing, distribution and sales presence in international markets. These international operations are subject to a number of special risks, in addition to the risks of our domestic business, including currency exchange rate fluctuations, differing protections of intellectual property, trade barriers, exchange controls, regional economic uncertainty, differing (and possibly more stringent) labor regulation, labor unrest, risk of governmental expropriation, domestic and foreign customs and tariffs, current and changing regulatory environments (including, but not limited to, the risks associated with the importation and exportation of products and raw materials), risk of failure of our foreign employees to comply with both U.S. and foreign laws, including antitrust laws, trade regulations and the Foreign Corrupt Practices Act, difficulty in obtaining distribution support, difficulty in staffing and managing widespread operations, differences in the availability and terms of financing, political instability and unrest and risks of increases in taxes. Also, in some foreign jurisdictions, we may be subject to laws limiting the right and ability of entities organized or operating therein to pay dividends or remit earnings to affiliated companies unless specified conditions are met. To the extent we are unable to effectively manage our international operations and these risks, our international sales may be adversely affected, we may be subject to additional and unanticipated costs, and we may be subject to litigation or regulatory action. As a consequence, our business, financial condition and results of operations could be seriously harmed.

Changes in the regulatory environment, including environmental, health, and safety regulations, could subject us to increased compliance and manufacturing costs, which could have a material adverse effect on our business.

Health and Safety Regulations. Certain of our products contain hard metals, including tungsten and cobalt. Hard metal dust is being studied for potential adverse health effects by organizations in both the U.S. and in Europe. Future studies on the health effects of hard metals may result in new regulations in the U.S. and Europe that may restrict or prohibit the use of, and exposure to, hard metal dust. New regulation of hard metals could require us to change our operations, and these changes could affect the quality of our products and materially increase our costs.

Environmental Regulations. We are subject to various environmental laws, and any violation of, or our liabilities under, these laws could adversely affect us. Our operations necessitate the use and handling of hazardous materials and, as a result, we are subject to various federal, state, local and foreign laws, regulations and ordinances relating to the protection of the environment, including those governing discharges to air and water, handling and disposal practices for solid and hazardous wastes, the cleanup of contaminated sites and the maintenance of a safe work place. These laws impose penalties, fines and other sanctions for noncompliance and liability for response costs, property damages and personal injury resulting from past and current spills, disposals or other releases of, or exposure to, hazardous materials. We could incur substantial costs as a result of noncompliance with or liability for cleanup or other costs or damages under these laws. We may be subject to more stringent environmental laws in the future. If more stringent environmental laws are enacted in the future, these laws could have a material adverse effect on our business, financial condition and results of operations.

Regulations affecting the mining and drilling industries or utilities industry. Some of our principal customers are mining and drilling or utility companies. Many of these customers supply coal, oil, gas or other fuels as a source for the production of utilities in the U.S. and other industrialized regions. The operations of these mining and drilling companies are geographically diverse and are subject to or impacted by a wide array of regulations in the jurisdictions where they operate, such as applicable environmental laws and regulations governing the operations of utilities. As a result of changes in regulations and laws relating to such industries, our customers' operations could be disrupted or curtailed by governmental authorities. The high cost of compliance with mining, drilling and environmental regulations may also induce customers to discontinue or limit their operations, and may discourage companies from developing new opportunities. As a result of these factors, demand for our mining- and drilling-related products could be substantially affected by regulations adversely impacting the mining and drilling industries or altering the consumption patterns of utilities.

Our continued success depends on our ability to protect and defend our intellectual property. Our future success depends in part upon our ability to protect and defend our intellectual property. We rely principally on nondisclosure agreements and other contractual arrangements and trade secret law and, to a lesser extent, trademark and patent law, to protect our intellectual property. However, these measures may be inadequate to protect our intellectual property from infringement by others or prevent misappropriation of our proprietary rights. In addition, the laws of some foreign countries do not protect proprietary rights to the same extent as do U.S. laws. If one of our patents is infringed upon by a third party, we may need to devote significant time and financial resources to attempt to halt the infringement. We may not be successful in defending the patents involved in such a dispute. Similarly, while we do not knowingly infringe on patents, copyrights or other intellectual property rights owned by other parties, we may be required to spend a significant amount of time and financial resources to resolve any infringement claims against us. We may not be successful in defending our position or negotiating an alternative remedy. Our inability to protect our proprietary information and enforce or defend our intellectual property rights in proceedings initiated by or against us could have a material adverse effect on our business, financial condition and results of operations.

We operate in a highly competitive environment. Our domestic and foreign operations are subject to significant competitive pressures. We compete directly and indirectly with other manufacturers and suppliers of metalworking tools, engineered components and advanced materials. Some of our competitors are larger than we are, and may have greater access to financial resources or be less leveraged than us. In addition, the industry in which our products are used is a large, fragmented industry that is highly competitive.

If we are unable to retain our qualified management and employees, our business may be negatively affected. Our ability to provide high quality products and services depends in part on our ability to retain our skilled personnel in the areas of management, product engineering, servicing and sales. Competition for such personnel is intense and our competitors can be expected to attempt to hire our management and skilled employees from time to time. In addition, our strategies for growth are expected to place increased demands on our management skills and resources. If we are unable to retain our management team and professional personnel, our customer relationships and level of technical expertise could be negatively affected, which may materially and adversely affect our business.

Our future operating results may be affected by fluctuations in the prices and availability of raw materials. The raw materials we use for our products include ore concentrates, compounds and secondary materials containing tungsten, tantalum, titanium, niobium and cobalt. A significant portion of our raw materials are supplied by sources outside the U.S. The raw materials industry as a whole is highly cyclical, and at times pricing and supply can be volatile due to a number of factors beyond our control, including natural disasters, general economic and political conditions, labor costs, competition, import duties, tariffs and currency exchange rates. This volatility can significantly affect our raw material costs. In an environment of increasing raw material prices, competitive conditions can affect how much of the price increases in raw materials that we can recover in the form of higher sales prices for our products. To the extent we are unable to pass on any raw material price increases to our customers, our profitability could be adversely affected. Furthermore, restrictions in the supply of tungsten, cobalt and other raw materials could adversely affect our operating results. If the prices for our raw materials increase or we are unable to secure adequate supplies of raw materials on favorable terms, our profitability could be impaired.

Natural disasters or other global or regional catastrophic events could disrupt our operations and adversely affect results. Despite our concerted effort to minimize risk to our production capabilities and corporate information systems and to reduce the effect of unforeseen interruptions to us through business continuity planning, we still may be exposed to interruptions due to catastrophe, natural disaster, pandemic, terrorism or acts of war, which are beyond our control. Disruptions to our facilities or systems, or to those of our key suppliers, could also interrupt operational processes and adversely impact our ability to manufacture our products and provide services and support to our customers. As a result, our business, our results of operations, financial position, cash flows and stock price could be adversely affected.

We may not be able to manage and integrate acquisitions successfully. In the past, we have acquired companies and we continue to evaluate acquisition opportunities that have the potential to support and strengthen our business. We can give no assurances, however, that any acquisition opportunities will arise or if they do, that they will be consummated, or that additional financing, if needed, will be available on satisfactory terms. In addition, acquisitions involve inherent risks that the businesses acquired will not perform in accordance with our expectations. We may not be able to achieve the synergies and other benefits we expect from the integration of acquisitions as successfully or rapidly as projected, if at all. Our failure to effectively integrate newly acquired operations could prevent us from realizing our expected rate of return on an acquired business and could have a material and adverse effect on our results of operations and financial condition.

Product liability claims could have a material adverse effect on our business. The sale of metalworking, mining, highway construction and other tools and related products as well as engineered components and advanced materials entails an inherent risk of product liability claims. We cannot give assurance that the coverage limits of our insurance policies will be adequate or that our policies will cover any particular loss. Insurance can be expensive, and we may not always be able to purchase insurance on commercially acceptable terms, if at all. Claims brought against us that are not covered by insurance or that result in recoveries in excess of insurance coverage could have a material adverse effect on our business, financial condition and results of operations.

ITEM 1B – UNRESOLVED STAFF COMMENTS

None.

ITEM 2 – PROPERTIES

Our principal executive offices are located at 1600 Technology Way, P.O. Box 231, Latrobe, Pennsylvania, 15650. A summary of our principal manufacturing facilities and other materially important properties is as follows:

Location	Owned/Leased	Principal Products	Segment
United States:			
Irondale, Alabama	Owned	Custom Fabricated Wear Plate Solutions and Pins	AMSG
Birmingham, Alabama	Leased	Chromium Carbide Clad Pipes	AMSG
Rogers, Arkansas	Owned	Carbide Products	AMSG
Rogers, Arkansas	Leased	Pelletizing Die Plates	AMSG
Placentia, California	Leased	Wear Parts	AMSG
University Park, Illinois	Owned	Custom Fabricated Wear Plate Solutions	AMSG
Rockford, Illinois	Owned	Indexable Tooling	MSSG
New Albany, Indiana	Leased	High Wear Coating for Steel Parts	AMSG
Greenfield, Massachusetts	Owned	High-Speed Steel Taps	MSSG
Shelby Township, Michigan	Leased	Thermal Deburring and High Energy Finishing	AMSG
Traverse City, Michigan	Owned	Wear Parts	AMSG
Walker, Michigan	Leased	Thermal Energy Machining	AMSG
Elko, Nevada	Owned	Custom Fabricated Wear Plate Solutions	AMSG
Fallon, Nevada	Owned	Metallurgical Powders	MSSG/AMSG
Asheboro, North Carolina	Owned	High-Speed Steel and Carbide Round Tools	MSSG
Henderson, North Carolina	Owned	Metallurgical Powders	MSSG
Roanoke Rapids, North Carolina	Owned	Metalworking Inserts	MSSG
Cleveland, Ohio	Leased	Distribution	MSSG
Orwell, Ohio	Owned	Metalworking Inserts	MSSG
Solon, Ohio	Owned	Metalworking Toolholders	MSSG
Whitehouse, Ohio	Owned	Metalworking Inserts and Round Tools	MSSG
Bedford, Pennsylvania	Owned	Mining and Construction Tools and Wear Parts	AMSG
Bedford, Pennsylvania	Leased	Distribution	AMSG
Irwin, Pennsylvania	Owned	Carbide Wear Parts	AMSG
Irwin, Pennsylvania	Leased	Abrasive Flow Machining	AMSG
Latrobe, Pennsylvania	Owned	Metallurgical Powders	AMSG
Nenshannock, Pennsylvania	Leased	Specialty Metals and Alloys	AMSG
Union, Pennsylvania	Owned	Specialty Metals and Alloys	AMSG
Johnson City, Tennessee	Owned	Metalworking Inserts	MSSG
Lyndonville, Vermont	Owned	High-Speed Steel Taps	MSSG
Chilhowie, Virginia	Owned	Mining and Construction Tools and Wear Parts	AMSG
New Market, Virginia	Owned	Metalworking Toolholders	MSSG
International:			
Indaiatuba, Brazil	Leased	Metalworking Carbide Drills and Metalworking Toolholders	MSSG
Victoria, Canada	Owned	Wear Parts	AMSG
Fengpu, China	Owned	Intermetallic Composite Ceramic Powders and Parts	AMSG
Tianjin, China	Owned	Metalworking Inserts and Carbide Round Tools	MSSG
Xuzhou, China	Owned	Mining Tools	AMSG
Kingswinford, England	Leased	Distribution	MSSG
Boutheon Cedex, France	Owned	Metalworking Inserts	MSSG
Ebermannstadt, Germany	Owned	Metalworking Inserts	MSSG
Essen, Germany	Owned	Metallurgical Powders and Wear Parts	MSSG
Konigsee, Germany	Leased	Metalworking Carbide Drills	MSSG
Lichtenau, Germany	Owned	Metalworking Toolholders	MSSG
Mistelgau, Germany	Owned	Metallurgical Powders, Metalworking Inserts and Wear Parts	MSSG/AMSG

Location	Owned/Leased	Principal Products	Segment
International:			
Nabburg, Germany	Owned	Metalworking Toolholders	MSSG
Nabburg, Germany	Owned	Metalworking Round Tools, Drills and Mills	MSSG
Nuenkirchen, Germany	Owned	Distribution	MSSG
Vohenstrauss, Germany	Owned	Metalworking Carbide Drills	MSSG
Bangalore, India	Owned	Metalworking Inserts and Toolholders and Wear Parts	MSSG/AMSG
Shlomi, Israel	Owned	High-Speed Steel and Carbide Round Tools	MSSG
Milan, Italy	Owned	Metalworking Cutting Tools	MSSG
Arnhem, Netherlands	Owned	Wear Products	AMSG
Hardenberg, Netherlands	Owned	Wear Products	AMSG
Zory, Poland	Leased	Mining and Construction Conicals	AMSG
Barcelona, Spain	Leased	Metalworking Cutting Tools	MSSG
Vitoria, Spain	Leased	Metalworking Carbide Round Tools	MSSG
Newport, United Kingdom	Owned	Intermetallic Composite Powders	AMSG

We also have a network of warehouses and customer service centers located throughout North America, Europe, India, Asia Pacific and Latin America, a significant portion of which are leased. The majority of our research and development efforts are conducted in a corporate technology center located adjacent to our world headquarters in Latrobe, Pennsylvania, U.S., as well as in our facilities in Rogers, Arkansas, U.S.; Fuerth, Germany and Essen, Germany.

We use all significant properties in the businesses of powder metallurgy, tools, tooling systems, engineered components and advanced materials. Our production capacity is adequate for our present needs. We believe that our properties have been adequately maintained, are generally in good condition and are suitable for our business as presently conducted.

ITEM 3 - LEGAL PROCEEDINGS

The information set forth in Part I herein under the caption "Regulation" is incorporated into this Item 3. There are no material pending legal proceedings to which Kennametal or any of our subsidiaries is a party or of which any of our property is the subject. We are, however, periodically subject to legal proceedings and claims that arise in the ordinary course of our business.

ITEM 4 - SUBMISSION OF MATTERS TO A VOTE OF SECURITY HOLDERS

During the fourth quarter of 2009, there were no matters submitted to a vote of security holders through the solicitation of proxies or otherwise.

EXECUTIVE OFFICERS OF THE REGISTRANT

Incorporated by reference into this Part I is the information set forth in Part III, Item 10 under the caption "Executive Officers of the Registrant."

PART II

ITEM 5 - MARKET FOR THE REGISTRANT'S COMMON EQUITY, RELATED SHAREOWNER MATTERS AND ISSUER PURCHASES OF EQUITY SECURITIES

Our capital stock is traded on the New York Stock Exchange (symbol KMT). The number of shareowners of record as of July 31, 2009 was 2,427. Stock price ranges and dividends declared and paid have been restated to reflect the Company's 2-for-1 stock split completed in December 2007 and were as follows:

Quarter ended	September 30	December 31	March 31	June 30
2009				
High	\$ 38.75	\$ 27.90	\$ 24.10	\$ 22.40
Low	26.21	12.82	13.16	15.56
Dividends	0.12	0.12	0.12	0.12
2008				
High	\$ 44.93	\$ 45.61	\$ 38.03	\$ 38.75
Low	34.90	36.01	26.00	29.44
Dividends	0.105	0.12	0.12	0.12

See Note 2 in our consolidated financial statements set forth in Item 8 (Note 2) for information concerning our 2008 capital stock split.

The information incorporated by reference in Item 12 of this annual report on Form 10-K from our 2009 Proxy Statement under the heading "Equity Compensation Plans – Equity Compensation Plan Information" is hereby incorporated by reference into this Item 5.

PERFORMANCE GRAPH

The following graph compares cumulative total shareowner return on our capital stock with the cumulative total shareowner return on the common equity of the companies in the Standard & Poor's Mid-Cap 400 Market Index (S&P Mid-Cap 400), the Standard & Poor's Composite 1500 Market Index (S&P Composite), and two peer groups of companies determined by us (New Peer Group and Old Peer Group) for the period from July 1, 2004 to June 30, 2009.

On July 1, 2008, we established the New Peer Group which we believe is more representative of Kennametal's peers. We have included both this New Peer Group as well as the Old Peer Group in the comparisons below. The peer groups were created to benchmark our sales and earnings growth, return on invested capital, profitability and asset management.

The New Peer Group consists of the following companies: Allegheny Technologies Incorporated; Ametek Inc.; Barnes Group Inc.; Carpenter Technology Corporation; Crane Co.; Donaldson Company, Inc.; Dresser-Rand Group Inc.; Flowserve Corp.; Greif Inc.; Harsco Corporation; Joy Global Inc.; Lincoln Electric Holdings, Inc.; Pall Corporation.; Parker-Hannifin Corporation; Pentair Inc.; Sauer-Danfoss, Inc.; Teleflex, Incorporated; and The Timken Co.

The Old Peer Group consists of the following companies: Allegheny Technologies Incorporated; Carpenter Technology Corporation; Crane Co.; Danaher Corporation; Eaton Corporation; Flowserve Corp.; Harsco Corporation; Illinois Tool Works, Inc.; Joy Global Inc.; Lincoln Electric Holdings, Inc.; MSC Industrial Direct Co. Inc.; Parker-Hannifin Corporation; Pentair Inc.; Precision Castparts Corp.; Sauer-Danfoss, Inc.; Teleflex, Incorporated; and The Timken Co.

Comparison of 5-Year Cumulative Total Return

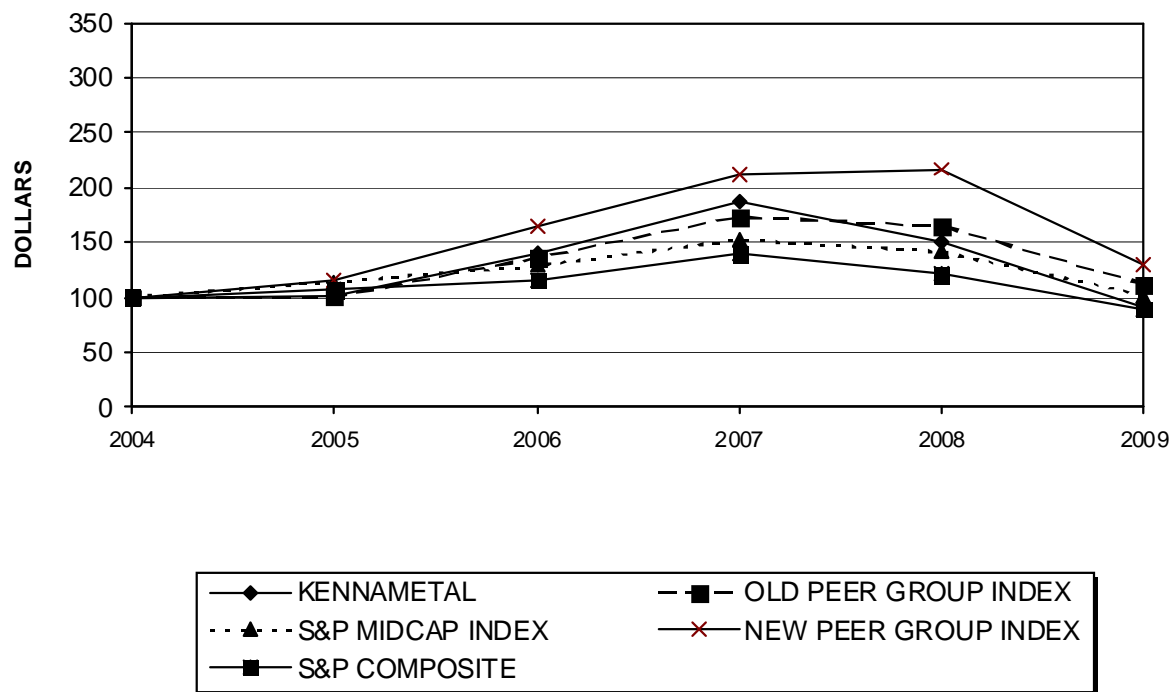

Assumes \$100 Invested on July 1, 2004 and All Dividends Reinvested

	2004	2005	2006	2007	2008	2009
Kennametal	\$100.00	\$101.59	\$139.87	\$186.79	\$150.12	\$90.49
Old Peer Group Index	100.00	100.32	136.46	173.16	165.04	112.02
New Peer Group Index	100.00	115.85	164.14	212.70	217.04	130.12
S&P Mid-Cap Index	100.00	114.03	128.83	152.67	141.47	101.83
S&P Composite	100.00	106.32	115.50	139.28	121.01	89.28

ISSUER PURCHASES OF EQUITY SECURITIES

Period	Total Number of Shares Purchased ⁽¹⁾	Average Price Paid per Share	Total Number of Shares Purchased as Part of Publicly Announced Plans or Programs	Maximum Number of Shares that May Yet Be Purchased Under the Plans or Programs
April 1 through April 30, 2009	231	\$ 16.15	-	-
May 1 through May 31, 2009	3,967	18.54	-	-
June 1 through June 30, 2009	14	20.00	-	-
Total	4,212	\$ 18.41	-	-

1) During the period, employees delivered 245 shares of restricted stock to Kennametal, upon vesting, to satisfy tax-withholding requirements. During the period, 3,967 shares were purchased on the open market on behalf of Kennametal to fund the Company's dividend reinvestment program.

ITEM 6 - SELECTED FINANCIAL DATA

		2009	2008	2007	2006	2005
OPERATING RESULTS (in thousands)						
Sales	(1)	\$ 1,999,859	\$ 2,589,786	\$ 2,265,336	\$ 2,213,233	\$ 2,090,978
Cost of goods sold		1,423,320	1,682,715	1,438,137	1,399,310	1,338,969
Operating expense		489,567	594,187	543,952	569,572	549,431
Restructuring and asset impairment charges	(2)	173,656	39,891	5,970	-	4,707
Interest expense		27,244	31,586	28,999	30,941	27,236
(Benefit) provision for income taxes		(11,205)	62,754	68,251	170,369	57,705
(Loss) income from continuing operations	(3)	(102,402)	163,666	174,717	267,652	107,968
Net (loss) income	(4)	(119,742)	167,775	174,243	256,283	119,291
FINANCIAL POSITION (in thousands)						
Working capital		\$ 496,935	\$ 630,675	\$ 529,265	\$ 624,658	\$ 402,404
Total assets		2,346,974	2,784,349	2,606,227	2,435,272	2,092,337
Long-term debt, including capital leases, excluding current maturities		436,592	313,052	361,399	409,508	386,485
Total debt, including capital leases and notes payable		485,957	346,652	366,829	411,722	437,374
Total shareowners' equity		1,247,443	1,647,907	1,484,467	1,295,365	972,862
PER SHARE DATA ⁽⁷⁾						
Basic (loss) earnings from continuing operations		\$ (1.40)	\$ 2.13	\$ 2.28	\$ 3.48	\$ 1.46
Basic (loss) earnings	(5)	(1.64)	2.18	2.27	3.33	1.62
Diluted (loss) earnings from continuing operations		(1.40)	2.10	2.22	3.38	1.42
Diluted (loss) earnings	(6)	(1.64)	2.15	2.22	3.24	1.57
Dividends		0.48	0.47	0.41	0.38	0.34
Book value (at June 30)		17.03	21.44	19.04	16.78	12.76
Market Price (at June 30)		19.18	32.55	40.50	30.32	22.03
OTHER DATA (in thousands, except number of employees)						
Capital expenditures		\$ 104,842	\$ 163,489	\$ 92,001	\$ 79,593	\$ 88,552
Number of employees (at June 30)		11,584	13,673	13,947	13,282	13,970
Basic weighted average shares outstanding	(7)	73,122	76,811	76,788	76,864	73,848
Diluted weighted average shares outstanding	(7)	73,122	78,201	78,545	79,101	76,112
KEY RATIOS						
Sales (decline) growth		(22.8%)	14.3%	2.4%	5.8%	12.0%
Gross profit margin		28.8	35.0	36.5	36.8	36.0
Operating (loss) profit margin		(5.0)	10.0	11.7	21.2	9.2

1) We divested J&L Industrial Supply (J&L) effective June 1, 2006. J&L sales were \$0.3 billion for 2006 and \$0.3 billion for 2005.

2) In 2009, the charges related to an impairment of \$111.0 million for AMMSG goodwill and an AMMSG indefinite lived trademark as well as restructuring charges of \$62.6 million. In 2008, the charges related to an AMMSG goodwill impairment of \$35.0 million, as well as restructuring charges of \$4.9 million. In 2007, the charge related to the impairment of an indefinite lived MSSG trademark. In 2005, the charge related to an impairment of goodwill in our divested Full Service Supply segment.

3) In 2006, income from continuing operations includes net gain on divestitures of \$122.5 million.

4) Net (loss) income includes (loss) income from discontinued operations of (\$17.3) million, \$4.1 million, (\$0.5) million, (\$11.4) million, and \$11.3 million for 2009, 2008, 2007, 2006, and 2005, respectively.

5) Basic (loss) earnings per share includes basic (loss) earnings from discontinued operations per share of (\$0.24), \$0.05, (\$0.01), (\$0.15), and \$0.15 for 2009, 2008, 2007, 2006 and 2005, respectively.

6) Diluted (loss) earnings per share includes diluted (loss) earnings from discontinued operations per share of (\$0.24), \$0.05, (\$0.00), (\$0.14), and \$0.15 for 2009, 2008, 2007, 2006 and 2005, respectively.

7) Share and per share amounts have been restated to reflect the Company's 2-for-1 stock split completed in December 2007. See Note 2 for information concerning our 2008 capital stock split.

Note: Prior year amounts have been reclassified to reflect discontinued operations related to the 2009 divestiture of the high speed steel and related products business.

ITEM 7 - MANAGEMENT'S DISCUSSION AND ANALYSIS OF FINANCIAL CONDITION AND RESULTS OF OPERATION

The following discussion should be read in connection with the consolidated financial statements of Kennametal Inc. and the related footnotes. Unless otherwise specified, any reference to a "year" is to a fiscal year ended June 30. Additionally, when used in this annual report on Form 10-K, unless the context requires otherwise, the terms "we," "our" and "us" refer to Kennametal Inc. and its subsidiaries.

OVERVIEW Kennametal Inc. is a leading global supplier of tooling, engineered components and advanced materials consumed in production processes. We believe that our reputation for manufacturing excellence as well as our technological expertise and innovation in our principal products has enabled us to achieve a leading market presence in our primary markets. We believe that we are one of the largest global providers of consumable metalcutting tools and tooling supplies.

We entered fiscal year 2009 after delivering record sales in our fiscal year ended June 30, 2008. Our sales continued to grow during the first months of our fiscal year 2009 and we reported record September quarter sales for the three months ended September 30, 2008. Following that, global economic conditions and industrial activity deteriorated substantially with a further downward acceleration in the March 2009 quarter. This resulted in significantly lower industrial production and much lower demand for our products in all major geographic regions, as well as most industry and market sectors. This had a corresponding effect on our sales levels, operating performance and financial results.

For the full fiscal year 2009, our sales were \$2.0 billion, a decrease of 23 percent from the record \$2.6 billion achieved in the prior fiscal year. For 2009, we recorded a net loss of \$119.7 million, or \$1.64 per diluted share. Included in our 2009 results were pre-tax restructuring and asset impairment charges of \$173.7 million. Also included in our 2009 results was a loss on discontinued operations of \$17.3 million, including a loss on divestiture. These items, along with other charges related to our restructuring programs, as well as the impact of the severe global economic downturn, were the primary drivers for the net loss that we recorded for 2009. Benefits realized from our restructuring actions and other cost reduction actions, as well as higher price realization, helped to mitigate these items.

Despite recording a net loss for the year, we generated cash flow from operating activities of \$192.3 million during 2009. Also helping our cash flow, we reduced our capital expenditures by \$58.6 million from the prior year. We also took other steps to improve our financial position and enhance our liquidity, including two significant actions taken in July 2009 which involved the amendment of our revolving credit facility and the issuance of 8.1 million shares of our capital stock.

While undertaking our many actions to reduce costs and optimize cash flow during the challenging economic environment in 2009, we took additional steps to further enhance our products and capabilities and preserve our competitive strengths. As a result of all of our actions, we believe that we are well positioned and better prepared to perform well in an eventual economic upturn.

In response to the impact of the rapid and steep decline in global demand, we implemented and will continue to drive restructuring programs and other measures to reduce our manufacturing costs and operating expenses. In April 2008, we announced restructuring actions to rationalize certain manufacturing and service facilities, as well as other employment and cost reduction programs. In January 2009, we announced a global salaried workforce reduction. In April 2009, we announced further restructuring actions which involve additional employment and other cost reduction programs. For our restructuring program in total, we realized approximately \$50 million in pre-tax benefits from restructuring actions in 2009 and expect to realize approximately \$75 million of additional pre-tax benefits from these actions in 2010. This would bring the total annual ongoing pre-tax benefits from restructuring to approximately \$125 million.

In addition to our restructuring programs, we have taken and will continue to take other actions to adjust our costs and level of operations to the extent necessary and appropriate. These other actions included employee furloughs from March 2009 through June 2009 and the suspension of matching contributions to certain employee benefit plans effective March 2009. We also implemented salary reductions effective July 2009 which will remain in effect until business conditions improve to a level that will permit partial or full restoration of the previous employee compensation levels.

As a result of the impact of the severe downturn in the global economy, we recorded a non-cash pre-tax impairment charge related to two businesses within our AMSG segment during 2009. This charge amounted to \$111.0 million, of which \$100.2 million was for goodwill and \$10.8 million was for an indefinite-lived trademark.

Our sharp focus on cash flow generation and liquidity during 2009 included persistent diligence with receivable collection, close management of production and inventory levels and tight control over capital expenditures. We reduced inventory in each of the final three quarters of 2009 despite the rapid and steep drop-off in sales volumes. This included a \$60 million inventory reduction in the second half of the fiscal year. At the same time, we maintained high off-the-shelf inventory availability. Capital expenditures were reduced to \$12 million in the June 2009 quarter which is the lowest quarterly capital spending level since the December 2003 quarter.

Also providing us with additional cash as well as taking another positive step in shaping our business portfolio was the completion of the divestiture of our high speed steel drills business, including related product lines and assets (HSS) on June 30, 2009. The cash proceeds from this deal are \$29 million. We received \$2 million of these cash proceeds prior to closing and another \$24 million in July 2009. We expect to receive the remaining balance in the December 2009 quarter. For 2009, this divested business generated sales of \$81 million and essentially breakeven results.

Earlier in the fiscal year, we enhanced our business portfolio within the AMMSG segment with the acquisition of Tricon, a leading supplier of custom wear solutions in the surface and underground mining markets.

In addition, we invested further in technology and innovation to continue delivering a high level of new products to our customers. Research and development expenses totaled \$27.6 million for 2009. In 2009, we generated over 40 percent of our sales from new products.

Our financial position and liquidity were further bolstered by the amendment to our credit facility and the common stock issuance that we undertook in July 2009.

RESTRUCTURING ACTIONS During 2009, we continued to implement restructuring plans to reduce costs and improve operating efficiencies. These actions relate to the rationalization of certain manufacturing and service facilities as well as other employment and cost reduction programs. Restructuring and related charges recorded in 2009 amounted to \$73.3 million. This included \$64.7 million of restructuring charges of which \$2.1 million were related to inventory disposals and recorded as cost of goods sold. Restructuring related charges of \$8.8 million were recorded in cost of goods sold and a net restructuring benefit of \$0.2 million was recorded in operating expense. See Note 16 in our consolidated financial statements set forth in Item 8.

Total restructuring and related charges since the inception of our restructuring plans through June 30, 2009 were \$81.5 million. Including these charges, we expect to recognize approximately \$115 million of pre-tax charges related to our restructuring plans. The majority of the remaining charges are expected to be incurred by December 31, 2009, most of which are expected to be cash expenditures. We realized pre-tax benefits of approximately \$50 million from these actions in fiscal 2009 and expect to realize approximately \$75 million of additional pre-tax benefits in fiscal 2010. This would bring the annual ongoing pre-tax benefits from these actions to approximately \$125 million.

ACQUISITIONS AND DIVESTITURES On October 1, 2008, we acquired Tricon Metals and Services Inc. (Tricon) in our AMMSG segment for a net purchase price of \$64.1 million. Tricon is a leading supplier of custom wear solutions specializing in consumable proprietary steels for the surface and underground mining markets, including hard rock and coal. During 2009, we also made a small acquisition within our MSSG segment.

During 2008, we did not complete any material acquisitions or divestitures. However, we made two small acquisitions in Europe, both within our MSSG segment. Also during 2008, we divested two small, non-core businesses from our MSSG segment, one in the U.S. and one in Europe. Combined cash proceeds received were \$20.2 million and we recognized a combined loss on divestitures of \$0.6 million.

During 2007, we completed five acquisitions. Three of these acquisitions were in our AMMSG segment and two were within our MSSG segment.

DISCONTINUED OPERATIONS On June 30, 2009, we divested HSS from our MSSG segment as part of our continuing focus to shape our business portfolio and rationalize our manufacturing footprint. This divestiture was accounted for as discontinued operations. Cash proceeds from this divestiture were \$29 million, of which \$2 million was received prior to closing and \$24 million was received in July 2009. We expect to receive the remaining \$3 million in proceeds in the December 2009 quarter. For 2009, this divested business generated sales of \$81 million and essentially breakeven results. The pre-tax loss on the sale and related pre-tax charges of \$25.5 million, as well as the related tax effects, were recorded in discontinued operations. We expect to incur additional pre-tax charges related to this divestiture of \$4.0 million to \$7.0 million during the six months ending December 2009.

During 2007, we completed two other divestitures which were accounted for as discontinued operations. See Note 5 in our consolidated financial statements set forth in Item 8.

The following represents the results of discontinued operations for the years ended June 30:

(in thousands)	2009		2008		2007	
Sales	\$	80,630	\$	115,343	\$	135,191
(Loss) income from discontinued operations before income taxes	\$	(25,923)	\$	5,412	\$	1,879
Income tax (benefit) expense		(8,583)		1,303		2,353
(Loss) income from discontinued operations	\$	(17,340)	\$	4,109	\$	(474)

RESULTS OF CONTINUING OPERATIONS

SALES Sales of \$1,999.9 million in 2009 decreased 22.8 percent versus \$2,590.0 million in 2008. The decrease in sales was primarily due to organic sales decline of \$549.7 million and unfavorable foreign currency effects of \$62.7 million, partially offset by the net favorable impact of acquisitions and divestitures of \$22.3 million. As a result of the severe downturn in the global economy, organic sales declined in all major metalworking markets. Organic sales declined in our advanced materials business primarily due to lower sales in the surface finishing machines and services business, as well as the engineered products business.

Sales of \$2,590.0 million in 2008 increased 14.3 percent versus \$2,265.3 million in 2007. The increase in sales was primarily attributed to organic sales growth of \$97.9 million, the impact of acquisitions of \$86.8 million and favorable foreign currency effects of \$140.0 million. Regionally, organic sales growth was mostly driven by growth in European and Asia Pacific markets offset somewhat by weakness in the North American market. Organic sales growth by sector was led by year-over-year expansion in the aerospace, machine tools, general engineering, mining and highway construction markets.

GROSS PROFIT Gross profit decreased \$330.6 million to \$576.5 million in 2009 from \$907.1 million in 2008. The decrease was primarily due to lower organic sales volume, reduced absorption of manufacturing costs due to lower production levels, less favorable business unit mix, temporary disruption effects from restructuring programs, unfavorable foreign currency effects of \$12.9 million, an increase in restructuring and related charges of \$9.5 million. Improved price realization more than offset the impact of higher raw material costs. In addition, the benefits of restructuring and other cost reduction actions, lower provisions for incentive compensation programs as well as the net favorable impact of acquisitions and divestitures helped to mitigate the impact of lower sales and production volumes. The gross profit margin for 2009 decreased to 28.8 percent from 35.0 percent in 2008.

Gross profit increased \$79.9 million to \$907.1 million in 2008 from \$827.2 million in 2007. The 9.7 percent increase was primarily due to organic sales growth, the effect of acquisitions, the effects of price increases and the impact of favorable foreign currency effects of \$53.9 million. These benefits were partially offset by higher raw material costs, particularly products containing steel and cobalt, as well as a less favorable sales mix primarily due to a lower proportion of sales of energy-related products and lower performance in our surface finishing machines and services business. Gross profit for 2008 included restructuring charges of \$1.2 million related to inventory write-offs and \$0.2 million of other restructuring-related charges. The gross profit margin for 2008 decreased to 35.0 percent from 36.5 percent in 2007.

OPERATING EXPENSE Operating expense in 2009 was \$489.6 million, a decrease of \$104.6 million, or 17.6 percent, compared to \$594.2 million in 2008. The decrease is attributable to an \$80.0 million decrease in employment expenses driven by restructuring and cost management activities as well as lower provisions for incentive compensation programs of \$24.3 million, favorable foreign currency effects of \$15.0 million, a decrease in restructuring and related charges of \$2.1 million, and the impact of other cost reductions of \$16.6 million, offset somewhat by the net unfavorable impact of acquisitions and divestitures of \$9.1 million.

Operating expense in 2008 was \$594.2 million, an increase of \$50.2 million, or 9.2 percent, compared to \$544.0 million in 2007. The increase in operating expense was primarily due to unfavorable foreign currency effects of \$32.0 million, the impact of acquisitions of \$16.5 million, a \$5.9 million increase in employment costs and a \$5.7 million increase in professional fees, partially offset by a \$9.9 million decrease in other expenses. Operating expense for 2008 included restructuring-related charges of \$1.9 million.

RESTRUCTURING AND ASSET IMPAIRMENT CHARGES During 2009, we initiated certain restructuring actions and recognized \$64.7 million of restructuring charges of which \$62.6 million were recorded as restructuring charges and \$2.1 million were related to inventory disposals and recorded in cost of goods sold. See the discussion under the heading “Restructuring Actions” within this MD&A for additional information.

In the process of preparing our interim financial statements for the March 2009 quarter, we determined that the magnitude and duration of the economic downturn, as well as other factors, served as a triggering event for an impairment test of our surface finishing machines and services business as well as our engineered products business. These businesses are both part of our AMMSG segment. As a result of our test, we recorded a goodwill impairment charge of \$100.2 million. Of this amount, \$37.3 million related to our surface finishing machines and services business and \$62.9 million related to our engineered products business. No goodwill remains on the books for our surface finishing machines and services business. In addition, as a result of our impairment test, we recorded a \$10.8 million impairment charge for the indefinite-lived trademark for our surface finishing machines and services business in 2009.

We also recorded a goodwill impairment charge of \$35.0 million during 2008 for our surface finishing machines and services business. The charge was recorded as a result of a revised earnings forecast for the business due to a decline in operating performance and market weakness.

During 2007, we completed our strategic analysis and plan for our Widia brand. As a key element of our channel and brand strategy, we decided to leverage the strength of this brand to accelerate growth in the distribution market. Since demand in the distribution market is mostly for standard products and to further our relationship with our Widia distributors, we furthermore decided to migrate direct sales of Widia custom solutions products to the Kennametal brand. As a result, we recorded a pre-tax impairment charge of \$6.0 million related to our MSSG Widia trademark during 2007.

LOSS ON DIVESTITURES During 2008, we completed the divestitures of two non-core MSSG businesses for proceeds of \$20.2 million and recognized a net loss on divestitures of \$0.6 million. The results of operations for these businesses were not material and have not been presented as discontinued operations.

During 2007, we recorded a loss on divestiture of \$1.6 million as a result of a post-closing adjustment related to our divestiture of J&L Industrial Supply.

AMORTIZATION OF INTANGIBLES Amortization expense was \$13.1 million in 2009, a decrease of \$0.8 million from \$13.9 million in 2008. The decrease was due to some intangibles becoming fully amortized in 2009.

Amortization expense was \$13.9 million in 2008, an increase of \$4.0 million from \$9.9 million in 2007. The increase was due to the impact of acquisitions.

INTEREST EXPENSE Interest expense decreased \$4.4 million to \$27.2 million in 2009, compared with \$31.6 million in 2008. This decrease was due to lower average interest rates on domestic borrowings of 3.9 percent, compared to 6.2 percent in 2008. The portion of our debt subject to variable rates of interest was approximately 34 percent and 68 percent at June 30, 2009 and 2008, respectively. The decrease in the portion of our debt subject to variable rates was due to the termination in February 2009 of interest rate swap agreements to convert \$200 million of our fixed rate debt to floating rate debt.

Interest expense increased \$2.6 million to \$31.6 million in 2008, compared with \$29.0 million in 2007. This increase was primarily due to an increase in average domestic borrowings of \$110.2 million, offset in part by the effect of lower average interest rates on domestic borrowings of 6.2 percent, compared to 7.0 percent in 2007. The portion of our debt subject to variable rates of interest was approximately 68 percent and 53 percent at June 30, 2008 and 2007, respectively.

OTHER INCOME, NET In 2009, other income, net increased by \$12.2 million to \$14.6 million compared to \$2.4 million in 2008. The increase was primarily due to a favorable change in foreign currency transaction results of \$13.1 million.

In 2008, other income, net decreased by \$6.0 million to \$2.4 million compared to \$8.4 million in 2007. The decrease was due to unfavorable foreign currency transaction results of \$4.4 million, lower other income of \$1.6 million and lower interest income of \$0.6 million.

INCOME TAXES The effective tax rate from continuing operations for 2009 was 10.0 percent (benefit on a loss) compared to 27.4 percent (provision on income) for 2008. The change in the effective rate from 2008 to 2009 was primarily driven by asset impairment charges in both periods. In addition, the 2009 effective rate benefited from a valuation allowance adjustment in Europe as well as the settlement of a routine audit examination in the U.S. The 2008 effective rate was unfavorably impacted by a non-cash income tax charge related to a German tax reform bill that was enacted in the first quarter of 2008, but benefited from our dividend reinvestment plan in China.

The effective tax rate from continuing operations for 2008 was 27.4 percent compared to 27.8 percent for 2007. The decrease in the effective rate from 2007 to 2008 was primarily driven by a further increase in earnings under our pan-European business strategy, the combined effects of other international operations, and a tax benefit associated with a dividend reinvestment plan in China. The effects of these items were partially offset by the effect of the goodwill impairment charge related to our surface finishing machines and services businesses for which there was no tax benefit, and a non-cash income tax charge related to a German tax reform bill that was enacted in the first quarter of 2008.

During 2008, we made a change in our determination with respect to cumulative undistributed earnings of international subsidiaries and affiliates whereby we now consider unremitted previously taxed income of our international subsidiaries to not be permanently reinvested. As a result of this change, we accrued an income tax liability of \$3.0 million. Of this amount, \$2.1 million decreased accumulated other comprehensive income and \$0.9 million increased tax expense.

(LOSS) INCOME FROM CONTINUING OPERATIONS Loss from continuing operations was (\$102.4) million, or (\$1.40) per diluted share, in 2009 compared to income of \$163.7 million, or \$2.10 per diluted share, in 2008. The decrease in income from continuing operations was a result of the factors previously discussed.

Income from continuing operations was \$163.7 million, or \$2.10 per diluted share, in 2008 compared to \$174.7 million, or \$2.22 per diluted share, in 2007. The decrease in income from continuing operations was a result of the factors previously discussed.

BUSINESS SEGMENT REVIEW Our operations are organized into two reportable operating segments consisting of Metalworking Solutions & Services Group (MSSG) and Advanced Materials Solutions Group (AMSG), and Corporate. The presentation of segment information reflects the manner in which we organize segments for making operating decisions and assessing performance.

METALWORKING SOLUTIONS & SERVICES GROUP

(in thousands)	2009		2008		2007	
External sales	\$	1,191,759	\$	1,674,516	\$	1,457,077
Intersegment sales		139,509		174,004		135,502
Operating (loss) income		(19,180)		255,391		217,706

External sales of \$1,191.8 million in 2009 decreased by \$482.8 million, or 28.8 percent, from 2008. The decrease in sales was attributed to organic sales decline of 25 percent, unfavorable foreign currency effects of 3 percent and the effects of divestitures of 1 percent. On a global basis, industrial production declined sequentially and in comparison to the prior year. On a regional basis, Europe and North America reported organic sales declines of 27 percent and 26 percent, respectively. India, Asia Pacific and Latin America also experienced organic sales declines of 24 percent, 16 percent and 16 percent, respectively.

Operating loss for 2009 was \$19.2 million and reflects a decrease in operating performance of \$274.6 million or 107.5 percent, from the operating income generated in 2008. The primary drivers of the decline in operating performance were reduced sales volumes and the related lower manufacturing cost absorption due to lower production levels, as well as higher restructuring and related charges. This was offset in part by restructuring benefits and other cost reduction actions, as well as higher price realization. MSSG operating (loss) income included restructuring and related charges of \$52.9 million and \$4.9 million in 2009 and 2008, respectively.

External sales of \$1,674.5 million in 2008 increased by \$217.4 million, or 14.9 percent, from 2007. The increase in sales was attributed to organic sales growth of 5 percent, favorable foreign currency effects of 7 percent and the effects of acquisitions of 3 percent. The organic sales growth was driven by increases in Europe of 8 percent, Asia Pacific of 15 percent, India of 8 percent and Latin America of 9 percent partially offset by an organic sales decline in North America of 3 percent. Industrial activity remained positive in most industry sectors on a global basis, most notably aerospace, machine tools and general engineering. Favorable foreign currency effects were \$108.0 million for 2008.

Operating income for 2008 increased by \$37.7 million, or 17.3 percent, from 2007. These results benefited from sales growth as discussed above, favorable foreign currency effects, continued cost containment and the impact of acquisitions. MSSG operating income included restructuring and related charges of \$3.2 million and \$1.7 million for 2008 and 2007, respectively.

ADVANCED MATERIALS SOLUTIONS GROUP

(in thousands)	2009	2008	2007
External sales	\$ 808,100	\$ 915,270	\$ 808,259
Intersegment sales	17,805	39,131	42,881
Operating (loss) income	(39,539)	83,925	131,323

External sales of \$808.1 million in 2009 decreased by \$107.2 million, or 11.7 percent, from 2008. The decrease in sales was attributed to organic sales decline of 15 percent, unfavorable foreign currency effects of 2 percent, partially offset by the positive effects of acquisitions of 5 percent. The decrease in organic sales was driven by lower sales in the engineered products business, as well as reduced demand for surface finishing machines and services and energy related products.

Operating loss for 2009 was \$39.5 million and reflects a decrease of \$123.5 million, or 147.1 percent, from the operating income generated in 2008. The decrease was driven by lower sales and production volumes, as well as higher impairment and restructuring and related charges. A considerable portion of these impacts were offset by a combination of restructuring benefits and other cost reductions, as well as higher price realization. For 2009, operating loss included \$111.0 million of impairment charges and \$18.3 million of restructuring and related charges, compared to \$35.0 million of impairment charges and \$3.0 million of restructuring charges in 2008.

External sales of \$915.3 million in 2008 increased by \$107.0 million, or 13.2 percent, from 2007. The increase in sales was attributed to organic sales growth of 4 percent and the effects of acquisitions of 5 percent and favorable foreign currency effects of 4 percent. The increase in organic sales was driven by stronger mining and construction product sales, which were up 10 percent, and energy and related product sales, which were up 3 percent. Engineered product sales were flat in 2008. Favorable foreign currency effects were \$32.0 million for 2008.

Operating income for 2008 decreased \$47.4 million, or 36.1 percent, from 2007. The decrease in operating income was driven by a \$35.0 million goodwill impairment charge and higher raw material costs as well as lower performance related to our surface finishing machines and services business and a less favorable sales mix. AMSG operating income included restructuring charges of \$3.0 million for 2008.

CORPORATE

Corporate represents corporate shared service costs, certain employee benefit costs, certain employment costs, such as performance-based bonuses and stock-based compensation expense, and eliminations of operating results between segments.

(in thousands)	2009	2008	2007
Operating loss	\$ (41,099)	\$ (80,769)	\$ (83,290)

In 2009, operating loss decreased \$39.7 million, or 49.1 percent, from 2008. The decrease was primarily due to lower provisions for performance-based employee compensation programs of \$28.5 million as well as lower shared service and other costs principally from employment and other cost reduction actions. Corporate operating loss for 2009 also included \$2.1 million of restructuring and related costs.

In 2008, operating loss decreased \$2.5 million, or 3.0 percent, from 2007. The decrease was primarily due to lower shared services expense of \$6.6 million and reduced pension and other postretirement benefit expenses of \$3.5 million, partially offset by lower other income of \$5.6 million and higher employment costs of \$2.6 million. Corporate operating loss included \$0.3 million of restructuring-related costs for 2008.

LIQUIDITY AND CAPITAL RESOURCES Cash flow from operations is our primary source of funding for capital expenditures and internal growth. During the year ended June 30, 2009, cash flow provided by operating activities was \$192.3 million, which exceeded our investment in capital expenditures and business acquisitions for the year.

As an additional source of funds to meet our cash requirements, we have a five-year, multi currency, revolving credit facility entered into in March 2006 (2006 Credit Agreement) that extends to March 2011. The 2006 Credit Agreement permits revolving credit loans of up to \$500.0 million for working capital, capital expenditures and general corporate purposes. The 2006 Credit Agreement allows for borrowings in U.S. dollars, euro, Canadian dollars, pound sterling and Japanese yen. Interest payable under the 2006 Credit Agreement is based upon the type of borrowing under the facility and may be (1) LIBOR plus an applicable margin, (2) the greater of the prime rate or the Federal Funds effective rate plus 0.5 percent or (3) fixed as negotiated by us.

The 2006 Credit Agreement requires us to comply with various restrictive and affirmative covenants, including two financial covenants: a maximum leverage ratio and a minimum consolidated interest coverage ratio (as those terms are defined in the agreement). We were in compliance with these financial covenants as of June 30, 2009. Borrowings under the 2006 Credit Agreement as of June 30, 2009 were \$133.4 million.

Borrowings under the 2006 Credit Agreement are guaranteed by our significant domestic subsidiaries.

On July 6, 2009, we entered into an amendment to our 2006 Credit Agreement. The amendment provides for the exclusion of certain cash restructuring charges from the earnings component used in the calculation of the leverage and interest ratios. In addition, the amendment provides for an increase in the permitted leverage ratio for certain quarterly measurement dates. The amendment also provides restrictions on share repurchases and securitizations as well as future acquisitions and capital leases should leverage ratios exceed the permitted ratio that prevailed prior to the amendment. Furthermore, the amendment would require security interest in our domestic accounts receivable and inventories should our leverage ratio exceed a certain threshold. The amendment includes an increase in interest rates on borrowings of approximately 200 basis points.

Additionally, we obtain local financing through credit lines with commercial banks in the various countries in which we operate. At June 30, 2009, these borrowings amounted to \$28.2 million of notes payable and \$6.9 million of term debt and capital leases. We believe that cash flow from operations and the availability under our credit lines will be sufficient to meet our cash requirements over the next 12 months.

Based upon our debt structure at June 30, 2009 and 2008, approximately 34 percent and 68 percent of our debt, respectively, was exposed to variable rates of interest. The decrease in the portion of our debt subject to variable rates was due to the termination in February 2009 of interest rate swap agreements to convert \$200 million of our fixed rate debt to floating rate debt.

At June 30, 2009, we had cash and cash equivalents of \$69.8 million. Total shareowners' equity was \$1,247.4 million and total debt was \$486.0 million, including borrowings under the 2006 Credit Agreement, as of June 30, 2009. Our current senior credit ratings are at investment grade levels. We believe that our current financial position, liquidity and credit ratings provide access to the capital markets. We continue to closely monitor our liquidity position and the condition of the capital markets as well as the counterparty risk of our credit providers.

Also during July 2009, we completed the issuance of 8.1 million shares of common stock generating net proceeds of \$120.3 million which were used to pay down outstanding indebtedness under our revolving credit facility. This enhances our liquidity, further strengthens our financial position and provides us with additional operating flexibility during the current economic environment.

Following is a summary of our contractual obligations and other commercial commitments as of June 30, 2009 (in thousands):

Contractual Obligations		Total	2010	2011-2012	2013-2014	Thereafter
Long-term debt	(1) \$	516,366	\$ 40,315	\$ 475,961	\$ 90	\$ -
Notes payable	(2)	29,053	29,053	-	-	-
Pension benefit payments	(3)		37,353	76,513	84,824	(3)
Postretirement benefit payments	(3)		2,539	4,957	4,655	(3)
Capital leases	(4)	6,754	2,758	2,703	1,191	102
Operating leases		77,611	21,438	22,909	8,245	25,019
Purchase obligations	(5)	256,355	98,964	145,391	12,000	-
Unrecognized tax benefits	(6)	17,431	11,934	-	-	5,497
Total			\$ 244,354	\$ 728,434	\$ 111,005	

1) Long-term debt includes interest obligations of \$65.0 million. Interest obligations were determined assuming interest rates as of June 30, 2009 remain constant.

2) Notes payable includes interest obligations of \$0.8 million. Interest obligations were determined assuming interest rates as of June 30, 2009 remain constant.

3) Annual payments are expected to continue into the foreseeable future at the amounts noted in the table.

4) Capital leases include interest obligations of \$0.4 million.

5) Purchase obligations consist of purchase commitments for materials, supplies and machinery and equipment as part of the ordinary conduct of business. Purchase obligations with variable price provisions were determined assuming current market prices as of June 30, 2009 remain constant.

6) Unrecognized tax benefits are positions taken or expected to be taken on an income tax return that may result in additional payments to tax authorities. These amounts include interest of \$1.6 million accrued related to such positions as of June 30, 2009. The amount included for 2010 is expected to be settled within the next twelve months. The remaining amount of unrecognized tax benefits is included in the 'Thereafter' column as we are not able to reasonably estimate the timing of potential future payments. If a tax authority agrees with the tax position taken or expected to be taken or the applicable statute of limitations expires, then additional payments will not be necessary.

Other Commercial Commitments	Total	2010	2011-2012	2013-2014	Thereafter
Standby letters of credit	\$ 6,271	\$ 1,571	\$ 4,700	\$ -	\$ -
Guarantees	13,147	9,787	273	19	3,068
Total	\$ 19,418	\$ 11,358	\$ 4,973	\$ 19	\$ 3,068

The standby letters of credit relate to insurance and other activities.

Cash flows from discontinued operations are not deemed material and have been combined with cash flows from continuing operations within each cash flow statement category. The absence of cash flows from discontinued operations is not expected to have a material impact on our future liquidity and capital resources.

Cash Flow Provided by Operating Activities

During 2009, cash flow provided by operating activities was \$192.3 million, compared to \$279.8 million in 2008. Cash flow provided by operating activities for the current year consisted of net loss and non-cash items amounting to \$113.1 million of cash generation, including \$115.2 million of restructuring and asset impairment charges, plus cash provided by changes in certain assets and liabilities netting to \$79.2 million. Contributing to these changes was a decrease in accounts receivable of \$200.2 million and a decrease in inventories of \$36.0 million, partially offset by a decrease in accounts payable and accrued liabilities of \$118.1 million, a decrease in accrued income taxes of \$12.0 million and a decrease in other liabilities of \$26.9 million.

During 2008, cash flow provided by operating activities was \$279.8 million and consisted of net income and non-cash items totaling \$346.4 million, including \$39.9 million of restructuring and asset impairment charges, offset somewhat by net changes in certain assets and liabilities of \$66.6 million. Contributing to these changes were an increase in inventory of \$34.0 million due primarily to higher raw material prices and initiatives to increase service levels, an increase in accounts receivable of \$14.3 million and a decrease in accrued income taxes of \$9.7 million.

During 2007, cash flow provided by operating activities was \$199.0 million and consisted of net income and non-cash items totaling \$270.1 million offset somewhat by net changes in certain assets and liabilities of \$71.1 million. Contributing to these net changes were a \$31.1 million increase in accounts receivable due to higher sales volumes, a \$26.1 million increase in inventory due to higher sales volume and increased raw material inventory, an increase in accounts payable and accrued liabilities of \$39.3 million and a decrease in accrued income taxes of \$63.5 million primarily due to first quarter tax payments of \$86.2 million that mostly related to the gain on divestiture of J&L and cash repatriated during 2006 under the American Job Creation Act of 2004 (AJCA).

Cash Flow Used for Investing Activities

Cash flow used for investing activities was \$170.1 million for 2009, an increase of \$38.9 million, compared to \$131.2 million in 2008. During the current year, cash flow used for investing activities included \$104.8 million used for purchases of property, plant and equipment, which consisted primarily of equipment upgrades, and \$69.5 million used for the acquisition of business assets, primarily the Tricon acquisition with a net purchase price of \$64.1 million.

We have projected our capital expenditures for 2010 to be approximately \$60.0 million, which will be used primarily to invest in equipment upgrades and manufacturing capabilities. We believe this level of capital spending is sufficient to maintain competitiveness and improve productivity.

Cash flow used for investing activities was \$131.2 million in 2008, and included \$163.5 million used for purchases of property, plant and equipment, which consisted primarily of equipment upgrades and geographical expansion, partially offset by proceeds from divestitures of \$23.2 million and proceeds from the sale of investments in affiliated companies of \$5.9 million.

Cash flow used for investing activities was \$302.5 million in 2007, and included \$246.5 million used for the acquisition of business assets and \$92.0 million used for purchases of property, plant and equipment, which consisted primarily of equipment upgrades, partially offset by proceeds from divestitures of \$36.2 million.

Cash Flow Used for Financing Activities

Cash flow used for financing activities was \$15.5 million for 2009, compared to \$125.7 million in 2008. During the current year, cash flow used for financing activities included a \$128.0 million net increase in borrowings, \$12.6 million in proceeds from termination of interest rate swap agreements and \$4.9 million of dividend reinvestment and the effect of employee benefit and stock plans offset by \$127.7 million used for the repurchase of capital stock and \$35.5 million of cash dividends paid to shareowners.

In 2008, cash flow used for financing activities was \$125.7 million and included \$65.4 million for the repurchase of capital stock, a net decrease in borrowings of \$38.1 million and \$36.0 million of cash dividends paid to shareowners, partially offset by \$14.8 million of dividend reinvestment and the effects of employee benefit and stock plans.

In 2007, cash flow used for financing activities was \$82.7 million and included net decrease in borrowings of \$53.3 million, \$41.4 million for the repurchase of capital stock and \$31.8 million of cash dividends paid to shareowners, partially offset by \$50.9 million of dividend reinvestment and the effects of employee benefit and stock plans.

OFF-BALANCE SHEET ARRANGEMENTS We previously had an agreement with a financial institution whereby we were permitted to securitize, on a continuous basis, an undivided interest in a specific pool of our domestic trade accounts receivable. Pursuant to this agreement, we, and certain of our domestic subsidiaries, sold our domestic accounts receivable to Kennametal Receivables Corporation, a wholly-owned, bankruptcy-remote subsidiary. This agreement was discontinued in 2008.

At June 30, 2009 and 2008, there were no accounts receivables securitized under this program.

FINANCIAL CONDITION At June 30, 2009, total assets were \$2,347.0 million having decreased \$437.3 million from \$2,784.3 million at June 30, 2008. Total liabilities decreased \$35.4 million from \$1,114.9 million at June 30, 2008 to \$1,079.5 million at June 30, 2009.

Working capital was \$496.9 million at June 30, 2009, a decrease of \$133.8 million or 21.2 percent from \$630.7 million at June 30, 2008. The decrease in working capital was primarily driven by a decrease in accounts receivable of \$233.8 million and a decrease in inventory of \$79.5 million, increase in short-term debt of \$15.8 million, offset by an increase in other current assets of \$55.4 million, a decrease in accounts payable of \$101.9 million, and a decrease in accrued payroll of \$38.6 million. Foreign currency effects accounted for \$40.1 million, \$28.6 million, (\$0.5) million, \$3.4 million, (\$9.5) million and (\$7.8) million and were included in the change in accounts receivable, inventory, short-term debt, other current assets, accounts payable and accrued payroll, respectively.

Property, plant and equipment, net decreased \$29.5 million from \$749.8 million at June 30, 2008 to \$720.3 million at June 30, 2009, primarily due to depreciation expense of \$83.2 million and unfavorable foreign currency impact of \$33.5 million, divestitures and disposals of \$23.7 million, partially offset by capital additions of \$104.8 million.

At June 30, 2009, other assets were \$750.7 million, a decrease of \$131.9 million from \$882.6 million at June 30, 2008. The primary drivers for the reduction were a decrease in goodwill of \$105.5 million and a decrease in intangible assets of \$19.8 million. The decrease in goodwill was driven by write-downs related to impairment of \$100.2 million as well as unfavorable foreign currency effects of \$22.9 million and divestitures of \$5.8 million, partially offset by additions related to a business acquisition of \$23.4 million. The decrease in intangible assets was due to the write-down of a trademark intangible of \$10.8 million as well as unfavorable foreign currency translation effects of \$7.7 million and amortization of \$13.1 million, partially offset by additions related to business acquisitions of \$11.8 million.

Long-term debt and capital leases increased \$123.5 million to \$436.6 million at June 30, 2009 from \$313.1 million at June 30, 2008 primarily due to borrowings for the repurchase of capital stock of \$127.7 million.

Shareowners' equity was \$1,247.4 million at June 30, 2009, a decrease of \$400.5 million from \$1,647.9 million in the prior year. The increase was primarily attributed to a reduction in foreign currency translation adjustments of \$119.8 million, the purchase of capital stock of \$127.7 million, net loss of \$119.7 million and cash dividends paid to shareowners of \$35.5 million.

In July 2009, we completed the issuance of 8.1 million shares of our common stock generating net proceeds of \$120.3 million which were used to pay down outstanding indebtedness.

ENVIRONMENTAL MATTERS The operation of our business has exposed us to certain liabilities and compliance costs related to environmental matters. We are involved in various environmental cleanup and remediation activities at certain of our locations.

Superfund Sites We are involved as a PRP at various sites designated by the USEPA as Superfund sites. With respect to the Li Tungsten Superfund site in Glen Cove, New York, we remitted \$0.9 million in 2008 to the DOJ as payment in full settlement for its claim against us for costs related to that site and reversed the remaining accrual of \$0.1 million to operating expense. For certain of these sites, we have evaluated the claims and potential liabilities and have determined that neither are material, individually or in the aggregate. For certain other sites, proceedings are in the very early stages and have not yet progressed to a point where it is possible to estimate the ultimate cost of remediation, the timing and extent of remedial action that may be required by governmental authorities or the amount of our liability alone or in relation to that of any other PRPs.

Other Environmental Issues We establish and maintain reserves for other potential environmental issues. At June 30, 2009 and 2008, the total of accruals for these reserves was \$5.3 million and \$6.2 million, respectively. These totals represent anticipated costs associated with the remediation of these issues. Cash payments of \$0.1 million and \$1.0 million were made against these reserves during 2009 and 2008, respectively. We recorded favorable foreign currency translation adjustments of \$0.7 million during 2009 related to these reserves. We recorded unfavorable foreign currency translation adjustments of \$0.8 million during 2008 related to these reserves.

We maintain a Corporate EHS Department, as well as an EHS Steering Committee, to monitor compliance with environmental regulations and to oversee remediation activities. In addition, we have established an EHS coordinator at each of our global manufacturing facilities. Our financial management team periodically meets with members of the Corporate EHS Department and the Corporate Legal Department to review and evaluate the status of environmental projects and contingencies. On a quarterly basis, we review financial provisions and reserves for environmental contingencies and adjust these reserves when appropriate.

EFFECTS OF INFLATION Despite modest inflation in recent years, rising costs, in particular the cost of certain raw materials, continue to affect our operations throughout the world. We strive to minimize the effects of inflation through cost containment, productivity improvements and price increases under competitive conditions.

DISCUSSION OF CRITICAL ACCOUNTING POLICIES In preparing our financial statements in conformity with accounting principles generally accepted in the United States of America, we make judgments and estimates about the amounts reflected in our financial statements. As part of our financial reporting process, our management collaborates to determine the necessary information on which to base our judgments and develops estimates used to prepare the financial statements. We use historical experience and available information to make these judgments and estimates. However, different amounts could be reported using different assumptions and in light of different facts and circumstances. Therefore, actual amounts could differ from the estimates reflected in our financial statements. Our significant accounting policies are described in Note 2. We believe that the following discussion addresses our critical accounting policies.

Revenue Recognition We recognize revenue upon shipment of our products and assembled machines. Our general conditions of sale explicitly state that the delivery of our products and assembled machines is F.O.B. shipping point and that title and all risks of loss and damages pass to the buyer upon delivery of the sold products or assembled machines to the common carrier.

Our general conditions of sale explicitly state that acceptance of the conditions of shipment is considered to have occurred unless written notice of objection is received by Kennametal within 10 calendar days of the date specified on the invoice. We do not ship products or assembled machines unless we have documentation authorizing shipment to our customers. Our products are consumed by our customers in the manufacture of their products. Historically, we have experienced very low levels of returned products and assembled machines and do not consider the effect of returned products and assembled machines to be material. We have recorded an estimated returned goods allowance to provide for any potential returns.

We warrant that products and services sold are free from defects in material and workmanship under normal use and service when correctly installed, used and maintained. This warranty terminates 30 days after delivery of the product to the customer, and does not apply to products that have been subjected to misuse, abuse, neglect or improper storage, handling or maintenance. Products may be returned to Kennametal only after inspection and approval by Kennametal and upon receipt by the customer of shipping instructions from Kennametal. We have included an estimated allowance for warranty returns in our returned goods allowance discussed above.

We recognize revenue related to the sale of specialized assembled machines upon customer acceptance and installation, as installation is deemed essential to the functionality of a specialized assembled machine. Sales of specialized assembled machines were immaterial for 2009, 2008 and 2007.

Stock-Based Compensation We recognize stock-based compensation expense for all stock options, restricted stock awards and restricted stock units over the period from the date of grant to the date when the award is no longer contingent on the employee providing additional service (substantive vesting period). We continue to follow the nominal vesting period approach for unvested awards granted prior to the adoption of Statement of Financial Accounting Standard (SFAS) No. 123(R), "Share-Based Payment (revised 2004)" on July 1, 2005. We utilize the Black-Scholes valuation method to establish the fair value of all awards.

Accounting for Contingencies We accrue for contingencies when it is probable that a liability or loss has been incurred and the amount can be reasonably estimated. Contingencies by their nature relate to uncertainties that require the exercise of judgment in both assessing whether or not a liability or loss has been incurred and estimating the amount of probable loss. The significant contingencies affecting our financial statements include environmental, health and safety matters and litigation.

Long-Lived Assets We evaluate the recoverability of property, plant and equipment and intangible assets that are amortized whenever events or changes in circumstances indicate the carrying amount of any such assets may not be fully recoverable. Changes in circumstances include technological advances, changes in our business model, capital structure, economic conditions or operating performance. Our evaluation is based upon, among other things, our assumptions about the estimated future undiscounted cash flows these assets are expected to generate. When the sum of the undiscounted cash flows is less than the carrying value, we will recognize an impairment loss to the extent that carrying value exceeds fair value. We apply our best judgment when performing these evaluations to determine if a triggering event has occurred, the undiscounted cash flows used to assess recoverability and the fair value of the asset.

Goodwill and Indefinite-Lived Intangible Assets We evaluate the recoverability of goodwill of each of our reporting units by comparing the fair value of each reporting unit with its carrying value. The fair values of our reporting units are determined using a combination of a discounted cash flow analysis and market multiples based upon historical and projected financial information. We apply our best judgment when assessing the reasonableness of the financial projections used to determine the fair value of each reporting unit. We evaluate the recoverability of indefinite-lived intangible assets using a discounted cash flow analysis based on projected financial information. This evaluation is sensitive to changes in market interest rates.

Pension and Other Postretirement and Postemployment Benefits We sponsor these types of benefit plans for a majority of our employees and retirees. Accounting for the cost of these plans requires the estimation of the cost of the benefits to be provided well into the future and attributing that cost over the expected work life of employees participating in these plans. This estimation requires our judgment about the discount rate used to determine these obligations, expected return on plan assets, rate of future compensation increases, rate of future health care costs, withdrawal and mortality rates and participant retirement age. Differences between our estimates and actual results may significantly affect the cost of our obligations under these plans.

In the valuation of our pension and other postretirement and postemployment benefit liabilities, management utilizes various assumptions. We determine our discount rate based on investment grade bond yield curves with a duration that approximates the benefit payment timing of each plan. This rate can fluctuate based on changes in investment grade bond yields. At June 30, 2009, a hypothetical 25 basis point increase or decrease in our discount rates would increase or decrease, respectively, our pre-tax income by approximately \$0.3 million.

The long-term rate of return on plan assets is estimated based on an evaluation of historical returns for each asset category held by the plans, coupled with the current and short-term mix of the investment portfolio. The historical returns are adjusted for expected future market and economic changes. This return will fluctuate based on actual market returns and other economic factors.

The rate of future health care cost increases is based on historical claims and enrollment information projected over the next fiscal year and adjusted for administrative charges. This rate is expected to decrease until 2029. At June 30, 2009, a hypothetical 1 percent increase or decrease in our health care cost trend rates would decrease or increase our pre-tax income by \$0.1 million.

Future compensation rates, withdrawal rates and participant retirement age are determined based on historical information. These assumptions are not expected to significantly change. Mortality rates are determined based on a review of published mortality tables.

We expect to contribute \$7.3 million and \$2.3 million to our pension and other postretirement benefit plans, respectively, in 2010.

Allowance for Doubtful Accounts We record allowances for estimated losses resulting from the inability of our customers to make required payments. We assess the creditworthiness of our customers based on multiple sources of information and analyze additional factors such as our historical bad debt experience, industry and geographic concentrations of credit risk, current economic trends and changes in customer payment terms. This assessment requires significant judgment. If the financial condition of our customers was to deteriorate, additional allowances may be required, resulting in future operating losses that are not included in the allowance for doubtful accounts at June 30, 2009.

Inventories Inventories are stated at the lower of cost or market. We use the last-in, first-out method for determining the cost of a significant portion of our U.S. inventories. The cost of the remainder of our inventories is determined under the first-in, first-out or average cost methods. When market conditions indicate an excess of carrying costs over market value, a lower-of-cost-or-market provision is recorded. Excess and obsolete inventory reserves are established based upon our evaluation of the quantity of inventory on hand relative to demand.

Income Taxes Realization of our deferred tax assets is primarily dependent on future taxable income, the timing and amount of which are uncertain in part due to the expected profitability of certain foreign subsidiaries. A valuation allowance is recognized if it is “more likely than not” that some or all of a deferred tax asset will not be realized. As of June 30, 2009, the deferred tax assets net of valuation allowances relate primarily to net operating loss carryforwards, accrued employee benefits and inventory reserves. In the event that we were to determine that we would not be able to realize our deferred tax assets in the future, an increase in the valuation allowance would be required.

NEW ACCOUNTING STANDARDS On June 30, 2009, Kennametal adopted SFAS No. 165, “Subsequent Events,” (SFAS 165). SFAS 165 establishes general standards of accounting for and disclosure of events that occur after the balance sheet date but before financial statements are issued or are available to be issued. Specifically, SFAS 165 sets forth the period after the balance sheet date during which management of a reporting entity should evaluate events or transactions that may occur for potential recognition or disclosure in the financial statements, the circumstances under which an entity should recognize events or transactions occurring after the balance sheet date in its financial statements, and the disclosures that an entity should make about events or transactions that occurred after the balance sheet date. See Note 24 for additional disclosures.

On June 30, 2009, Kennametal adopted Financial Accounting Standards Board (FASB) Staff Position (FSP) No. FAS 157-4, “Determining Fair Value When the Volume and Level of Activity for the Asset or Liability Have Significantly Decreased and Identifying Transactions That Are Not Orderly” (FSP 157-4). FSP 157-4 provides guidance on factors to be considered while estimating fair value in accordance with SFAS No. 157, “Fair Value Measurements” (SFAS 157), when there has been a significant decrease in market activity for an asset or liability. This guidance retains the existing “exit price” concept under SFAS 157 and therefore does not change the objective of fair value measurements, even when there has been a significant decrease in market activity. The adoption of FSP 157-4 did not have an impact on our consolidated financial statements.

In June 2009, the FASB issued SFAS No. 168, “The FASB Accounting Standards Codification and the Hierarchy of Generally Accepted Accounting Principles” (SFAS 168). SFAS 168 replaces FASB Statement No. 162, “The Hierarchy of Generally Accepted Accounting Principles.” The FASB Accounting Standards Codification (Codification) is the single source of authoritative nongovernmental accounting principles generally accepted in the United States of America (U.S. GAAP). The Codification does not change current U.S. GAAP, but is intended to simplify user access to all authoritative U.S. GAAP by providing all the authoritative literature related to a particular topic in one place. All existing accounting standard documents will be superseded and all other accounting literature not included in the Codification will be considered non-authoritative. SFAS 168 is effective for Kennametal as of September 30, 2009. We are in the process of evaluating the provisions of SFAS 168 to determine the impact of the Codification on our financial reporting process and for providing Codification references in our public filings.

In June 2009, the FASB issued SFAS No. 167, “Amendments to FASB Interpretation No. 46(R)” (SFAS 167). SFAS 167 modifies how a company determines when an entity that is insufficiently capitalized or is not controlled through voting (or similar rights) should be consolidated. SFAS 167 clarifies that the determination of whether a company is required to consolidate an entity is based on, among other things, an entity’s purpose and design and a company’s ability to direct the activities of the entity that most significantly impact the entity’s economic performance. SFAS 167 requires an ongoing reassessment of whether a company is the primary beneficiary of a variable interest entity. SFAS 167 also requires additional disclosures about a company’s involvement in variable interest entities and any significant changes in risk exposure due to that involvement. SFAS 167 is effective for Kennametal Inc. beginning July 1, 2010. We are in the process of evaluating the provisions of SFAS 167 to determine the impact of adoption on our consolidated financial statements.

In June 2009, the FASB issued SFAS No. 166, “Accounting for Transfers of Financial Assets — an amendment of FASB Statement No. 140” (SFAS 166). SFAS 166 requires additional information regarding transfers of financial assets, including securitization transactions, and where companies have continuing exposure to the risks related to transferred financial assets. SFAS 166 eliminates the concept of a “qualifying special-purpose entity,” changes the requirements for derecognizing financial assets, and requires additional disclosures. SFAS 166 is effective for Kennametal beginning July 1, 2010. We are in the process of evaluating the provisions of SFAS 166 to determine the impact of adoption on our consolidated financial statements.

In April 2009, the FASB issued FSP No. FAS 107-1 and APB 28-1, “Interim Disclosure about Fair Value of Financial Instruments” (FSP 107-1). FSP 107-1 expands the fair value disclosures to interim periods for all financial instruments that are within the scope of SFAS No. 107, “Disclosures about Fair Value of Financial Instruments.” This FSP also requires entities to disclose the methods and significant assumptions used to estimate the fair value of financial instruments as well as significant changes in such methods and assumptions from prior periods. FSP 107-1 is effective for Kennametal as of September 30, 2009. We are in the process of evaluating the provisions of this FSP to determine the impact of adoption on our consolidated financial statements.

In April 2009, the FASB issued FSP No. FAS 141(R)-1, "Accounting for Assets Acquired and Liabilities Assumed in a Business Combination That Arise from Contingencies" (FSP 141(R)-1). This FSP amends the guidance in SFAS No. 141 (revised 2007), "Business Combinations" (SFAS 141(R)) and establishes a model to account for preacquisition contingencies. Under this FSP, an acquirer is required to recognize at fair value an asset or liability assumed in a business combination that arises from a contingency if the acquisition-date fair value can be determined during the measurement period. If the acquisition-date fair value cannot be determined, then the acquirer should follow the recognition criteria in SFAS No. 5, "Accounting for Contingencies" and FASB Interpretation No. 14, "Reasonable Estimation of the Amount of a Loss – an interpretation of FASB Statement No. 5," to determine whether the contingency should be recognized as of the acquisition date or after it. FSP 141(R)-1 is effective for Kennametal beginning July 1, 2009. We are in the process of evaluating the provisions of this FSP to determine the impact of adoption on our consolidated financial statements.

On January 1, 2009, Kennametal adopted SFAS No. 161, "Disclosures about Derivative Instruments and Hedging Activities—an amendment of FASB Statement No. 133" (SFAS 161) as it relates to derivatives and hedging activities. SFAS 161 expands the current disclosure requirements in SFAS No. 133, "Accounting for Derivative Instruments and Hedging Activities" (SFAS 133) and provides for an enhanced understanding of (1) how and why an entity uses derivative instruments, (2) how derivative instruments and related hedged items are accounted for under SFAS 133 and its related interpretations, and (3) how derivative instruments and related hedged items affect an entity's financial position, financial performance and cash flows. See Note 7 for additional disclosures.

In December 2008, the FASB issued FSP No. 132(R)-1, "Employers' Disclosures about Postretirement Benefit Plan Assets" (FSP 132(R)-1). FSP 132(R)-1 expands the current disclosure requirements in SFAS No. 132(R), "Employers' Disclosures about Pensions and Other Postretirement Benefits." FSP 132(R)-1 requires companies to disclose how investment allocation decisions are made by management, major categories of plan assets, significant concentrations of risk within plan assets and information about the valuation of plan assets. FSP 132(R)-1 is effective for Kennametal beginning July 1, 2009. We are in the process of evaluating the provisions of this FSP to determine the impact of adoption on our consolidated financial statements.

In November 2008, the FASB ratified Emerging Issues Task Force (EITF) Issue No. 08-7, "Accounting for Defensive Intangible Assets" (EITF 08-7). EITF 08-7 applies to all acquired intangible assets in situations in which the entity does not intend to actively use the asset but intends to hold the asset to prevent others from obtaining access to the asset with limited exceptions. EITF 08-7 requires that defensive intangible assets be accounted for as a separate unit of accounting and be assigned a useful life. EITF 08-7 is to be applied prospectively and is effective for Kennametal beginning July 1, 2009. We are in the process of evaluating the provisions of this EITF to determine the impact of adoption on our consolidated financial statements.

In November 2008, the FASB ratified EITF Issue No. 08-6, "Equity Method Investment Accounting Considerations" (EITF 08-6). EITF 08-6 addresses a number of matters associated with the impact that SFAS 141(R) and SFAS No. 160, "Noncontrolling Interest in Consolidated Financial Statements, an amendment of ARB No. 51" (SFAS 160) might have on the accounting for equity method investments. EITF 08-6 provides guidance on how an equity method investment should initially be measured, how it should be tested for impairment and how changes in classification from equity method to cost method should be treated as well as other issues. EITF 08-6 is to be applied prospectively and is effective for Kennametal beginning July 1, 2009. We are in the process of evaluating the provisions of this EITF to determine the impact of adoption on our consolidated financial statements.

On July 1, 2008, Kennametal adopted SFAS No. 159, "The Fair Value Option for Financial Assets and Financial Liabilities—Including an amendment of FASB Statement No. 115" (SFAS 159). SFAS 159 permits entities to choose to measure many financial instruments and certain other assets and liabilities at fair value on an instrument-by-instrument basis (the fair value option) with changes in fair value recognized in earnings at each subsequent reporting date. Kennametal records derivative contracts and hedging activities at fair value in accordance with SFAS 133. The adoption of SFAS 159 therefore had no impact on our consolidated financial statements as management did not elect the fair value option for any other financial instruments or certain other assets and liabilities.

On July 1, 2008, Kennametal adopted SFAS No. 157, "Fair Value Measurements" (SFAS 157) as it relates to financial assets and financial liabilities. In February 2008, the FASB issued FSP No. FAS 157-2, "Effective Date of FASB Statement No. 157," which delayed the effective date of SFAS 157 for all nonfinancial assets and nonfinancial liabilities, except those that are recognized or disclosed at fair value in the financial statements on at least an annual basis, until July 1, 2009 for Kennametal. See Note 6 for additional disclosures.

On July 1, 2008, Kennametal adopted EITF Issue No. 06-11, "Accounting for Income Tax Benefits of Dividends on Share-Based Payment Awards" (EITF 06-11). EITF 06-11 requires that tax benefits generated by dividends paid during the vesting period on certain equity-classified share-based compensation awards be classified as additional paid-in capital and included in a pool of excess tax benefits available to absorb tax deficiencies from share-based payment awards. The adoption of this EITF did not have a material impact on our consolidated financial statements.

In June 2008, the FASB issued FSP No. EITF 03-6-1, "Determining Whether Instruments Granted in Share-Based Payment Transactions Are Participating Securities," (FSP EITF 03-6-1). FSP EITF 03-6-1 states that unvested share-based payment awards that contain nonforfeitable rights to dividends or dividend equivalents (whether paid or unpaid) are participating securities and shall be included in the computation of earnings per share pursuant to the two-class method. FSP EITF 03-6-1 becomes effective for Kennametal on July 1, 2009. Management has determined that the adoption of FSP EITF 03-6-1 will not have a material impact on our consolidated financial statements.

In December 2007, the FASB issued SFAS No. 141(R), "Business Combinations" (SFAS 141(R)) which establishes principles and requirements for how an acquirer accounts for business combinations and includes guidance for the recognition, measurement and disclosure of the identifiable assets acquired, the liabilities assumed and any noncontrolling or minority interest in the acquiree. It also provides guidance for the measurement of goodwill, the recognition of contingent consideration and the accounting for pre-acquisition gain and loss contingencies, as well as acquisition-related transaction costs and the recognition of changes in the acquirer's income tax valuation allowance. SFAS 141(R) is to be applied prospectively and is effective for Kennametal beginning July 1, 2009. We are in the process of evaluating the provisions of SFAS 141(R) to determine the impact of adoption on our consolidated financial statements.

In December 2007, the FASB issued SFAS No. 160, "Noncontrolling Interests in Consolidated Financial Statements" (SFAS 160) which amends Accounting Research Bulletin No. 51, "Consolidated Financial Statements" to establish accounting and reporting standards for any noncontrolling interest in a subsidiary and for the deconsolidation of a subsidiary. SFAS 160 clarifies that a noncontrolling interest in a subsidiary should be reported as a component of equity in the consolidated financial statements and requires disclosure on the face of the consolidated statement of income of the amounts of consolidated net income attributable to the parent and to the noncontrolled interest. SFAS 160 is to be applied prospectively and is effective for Kennametal as of July 1, 2009, except for the presentation and disclosure requirements, which, upon adoption, will be applied retrospectively for all periods presented. We are in the process of evaluating the provisions of SFAS 160 to determine the impact of adoption on our consolidated financial statements.

ITEM 7A - QUANTITATIVE AND QUALITATIVE DISCLOSURES ABOUT MARKET RISK

MARKET RISK We are exposed to certain market risks arising from transactions that are entered into in the normal course of business. As part of our financial risk management program, we use certain derivative financial instruments to manage these risks. We do not enter into derivative transactions for speculative purposes and therefore hold no derivative instruments for trading purposes. We generally use derivative financial instruments to provide predictability to the effects of changes in foreign exchange rates on our consolidated results and to achieve our targeted mix of fixed and floating interest rates on outstanding debt. Our objective in managing foreign exchange exposures with derivative instruments is to reduce volatility in cash flow, allowing us to focus more of our attention on business operations. With respect to interest rate management, these derivative instruments allow us to achieve our targeted fixed-to-floating interest rate mix as a separate decision from funding arrangements in the bank and public debt markets. We measure hedge effectiveness by assessing the changes in the fair value or expected future cash flows of the hedged item. The ineffective portions are recorded in other income, net. See Notes 2 and 17 in our consolidated financial statements set forth in Item 8.

We are exposed to counterparty credit risk for nonperformance of derivative contracts and, in the event of nonperformance, to market risk for changes in interest and currency rates, as well as settlement risk. We manage exposure to counterparty credit risk through credit standards, diversification of counterparties and procedures to monitor concentrations of credit risk. We do not anticipate nonperformance by any of the counterparties.

The following provides additional information on our use of derivative instruments. Included below is a sensitivity analysis that is based upon a hypothetical 10 percent weakening or strengthening in the U.S. dollar compared to the June 30, 2009 foreign currency rates and the effective interest rates under our current borrowing arrangements. We compared the contractual derivative and borrowing arrangements in effect at June 30, 2009 to the hypothetical foreign exchange or interest rates in the sensitivity analysis to determine the effect on interest expense, pre-tax income or accumulated other comprehensive income. Our analysis takes into consideration the different types of derivative instruments and the applicability of hedge accounting.

CASH FLOW HEDGES *Currency* A portion of our operations consists of investments in foreign subsidiaries. Our exposure to market risk for changes in foreign exchange rates arises from these investments, intercompany loans utilized to finance these subsidiaries, trade receivables and payables and firm commitments arising from international transactions. We manage our foreign exchange transaction risk to reduce the volatility of cash flows caused by currency fluctuations through natural offsets where appropriate and through foreign exchange contracts. These contracts are designated as hedges of transactions that will settle in future periods and otherwise would expose us to foreign currency risk.

Our foreign exchange hedging program minimizes our exposure to foreign exchange rate movements. This exposure arises largely from anticipated cash flows from cross-border intercompany sales of products and services. This program utilizes range forwards and forward contracts primarily to sell foreign currency. The notional amounts of the contracts translated into U.S. dollars at June 30, 2009 and 2008 rates were \$1.7 million and \$126.5 million, respectively. We would have received \$0.2 million at June 30, 2009 and paid \$0.3 million at June 30, 2008, respectively, to settle these contracts, which represent the fair value of these agreements. At June 30, 2009, a hypothetical 10 percent strengthening or weakening of the U.S. dollar would change accumulated other comprehensive income (loss), net of tax, by \$0.1 million.

In addition, we may enter into forward contracts to hedge transaction exposures or significant cross-border intercompany loans by either purchasing or selling specified amounts of foreign currency at a specified date. At June 30, 2009 and 2008, we had several outstanding forward contracts to purchase and sell foreign currency, with notional amounts, translated into U.S. dollars at June 30, 2009 and 2008 rates, of \$183.2 million and \$111.4 million, respectively. At June 30, 2009, a hypothetical 10 percent change in the year-end exchange rates would result in an increase or decrease in pre-tax income of \$15.4 million related to these positions.

Interest Rate Our exposure to market risk for changes in interest rates relates primarily to our long-term debt obligations. We seek to manage our interest rate risk in order to balance our exposure between fixed and floating rates while attempting to minimize our borrowing costs. To achieve these objectives, we primarily use interest rate swap agreements to manage exposure to interest rate changes related to these borrowings. We had no such agreements in place at June 30, 2009 or June 30, 2008.

FAIR VALUE HEDGES *Interest Rate* As discussed above, our exposure to market risk for changes in interest rates relates primarily to our long-term debt obligations. We seek to manage this risk through the use of interest rate swap agreements. At June 30, 2009, we had no such agreements in place. In February 2009, we terminated interest rate swap agreements that we had in place at that time and at June 30, 2008. These previous agreements were in place to convert a notional amount of \$200.0 million of our fixed rate debt to floating rate debt.

DEBT AND NOTES PAYABLE At June 30, 2009 and 2008, we had \$486.0 million and \$346.7 million, respectively, of debt, including capital leases and notes payable outstanding. Effective interest rates as of June 30, 2009 and 2008 were 3.9 percent and 6.2 percent, respectively, including the effect of interest rate swaps. A hypothetical change of 10 percent in interest rates from June 30, 2009 levels would increase or decrease annual interest expense by approximately \$2.3 million.

On July 6, 2009, the Company entered into an amendment to its existing \$500.0 million revolving bank credit agreement, which expires on March 21, 2011. The amendment, among other things, retains the current size and maturity of the credit facility while providing additional flexibility with respect to financial covenants. The amendment includes an increase in interest rates on borrowings of approximately 200 basis points.

Also during July, the Company completed the issuance of 8.1 million shares of its common stock generating net proceeds of \$120.3 million which were used to pay down outstanding indebtedness under the revolving credit facility.

FOREIGN CURRENCY EXCHANGE RATE FLUCTUATIONS Foreign currency exchange rate fluctuations have materially increased earnings in 2009, 2008 and 2007. Foreign currency exchange rate fluctuations may have a material impact on future earnings in the short term and long term.

ITEM 8 - FINANCIAL STATEMENTS AND SUPPLEMENTARY DATA

MANAGEMENT'S REPORT ON INTERNAL CONTROL OVER FINANCIAL REPORTING

Management is responsible for establishing and maintaining adequate internal control over financial reporting. Management has conducted an assessment of the Company's internal controls over financial reporting as of June 30, 2009 using the criteria in *Internal Control – Integrated Framework*, issued by the Committee of Sponsoring Organizations of the Treadway Commission (COSO). The Company's internal control over financial reporting is designed to provide reasonable assurance regarding the reliability of financial reporting and the preparation of financial statements for external purposes in accordance with accounting principles generally accepted in the United States of America. Because of its inherent limitations, internal control over financial reporting may not prevent or detect misstatements. Also, projections of any evaluation of effectiveness to future periods are subject to the risk that controls may become inadequate because of changes in conditions, or that the degree of compliance with the policies or procedures may deteriorate.

Based on its assessment, management has concluded that the Company maintained effective internal control over financial reporting as of June 30, 2009, based on criteria in *Internal Control – Integrated Framework* issued by the COSO. The effectiveness of the Company's internal control over financial reporting as of June 30, 2009 has been audited by PricewaterhouseCoopers LLP, an independent registered public accounting firm, as stated in their report which appears herein.

MANAGEMENT'S CERTIFICATIONS

The certifications of the Chief Executive Officer and Chief Financial Officer required under Section 302 of the Sarbanes-Oxley Act have been filed as Exhibits 31.1 and 31.2 to this report. Additionally, in October 2008, the Chief Executive Officer filed with the New York Stock Exchange (NYSE) the annual certification required to be furnished to the NYSE pursuant to Section 303A.12 of the NYSE Listed Company Manual. The certification confirmed that the Chief Executive Officer was not aware of any violation by the Company of the NYSE's corporate governance listing standards.

Report of Independent Registered Public Accounting Firm

To the Shareowners of Kennametal Inc.:

In our opinion, the consolidated financial statements listed in the index appearing under Item 15(a)(1) present fairly, in all material respects, the financial position of Kennametal Inc. and its subsidiaries (the Company) at June 30, 2009 and 2008, and the results of their operations and their cash flows for each of the three years in the period ended June 30, 2009 in conformity with accounting principles generally accepted in the United States of America. In addition, in our opinion, the financial statement schedule listed in the index appearing under Item 15(a)(2) presents fairly, in all material respects, the information set forth therein when read in conjunction with the related consolidated financial statements. Also in our opinion, the Company maintained, in all material respects, effective internal control over financial reporting as of June 30, 2009, based on criteria established in *Internal Control - Integrated Framework* issued by the Committee of Sponsoring Organizations of the Treadway Commission (COSO). The Company's management is responsible for these financial statements and financial statement schedule, for maintaining effective internal control over financial reporting and for its assessment of the effectiveness of internal control over financial reporting, included in Management's Report on Internal Control over Financial Reporting appearing under Item 8. Our responsibility is to express opinions on these financial statements, on the financial statement schedule, and on the Company's internal control over financial reporting based on our integrated audits. We conducted our audits in accordance with the standards of the Public Company Accounting Oversight Board (United States). Those standards require that we plan and perform the audits to obtain reasonable assurance about whether the financial statements are free of material misstatement and whether effective internal control over financial reporting was maintained in all material respects. Our audits of the financial statements included examining, on a test basis, evidence supporting the amounts and disclosures in the financial statements, assessing the accounting principles used and significant estimates made by management, and evaluating the overall financial statement presentation. Our audit of internal control over financial reporting included obtaining an understanding of internal control over financial reporting, assessing the risk that a material weakness exists, and testing and evaluating the design and operating effectiveness of internal control based on the assessed risk. Our audits also included performing such other procedures as we considered necessary in the circumstances. We believe that our audits provide a reasonable basis for our opinions.

As discussed in Note 13 to the consolidated financial statements, the Company changed its method of accounting for uncertainty in income taxes in 2008. As discussed in Note 14 to the consolidated financial statements, the Company changed its method of accounting for defined benefit pension and other postretirement plans in 2007.

A company's internal control over financial reporting is a process designed to provide reasonable assurance regarding the reliability of financial reporting and the preparation of financial statements for external purposes in accordance with generally accepted accounting principles. A company's internal control over financial reporting includes those policies and procedures that (i) pertain to the maintenance of records that, in reasonable detail, accurately and fairly reflect the transactions and dispositions of the assets of the company; (ii) provide reasonable assurance that transactions are recorded as necessary to permit preparation of financial statements in accordance with generally accepted accounting principles, and that receipts and expenditures of the company are being made only in accordance with authorizations of management and directors of the company; and (iii) provide reasonable assurance regarding prevention or timely detection of unauthorized acquisition, use, or disposition of the company's assets that could have a material effect on the financial statements.

Because of its inherent limitations, internal control over financial reporting may not prevent or detect misstatements. Also, projections of any evaluation of effectiveness to future periods are subject to the risk that controls may become inadequate because of changes in conditions, or that the degree of compliance with the policies or procedures may deteriorate.

/s/ PricewaterhouseCoopers LLP
PricewaterhouseCoopers LLP
Pittsburgh, Pennsylvania
August 12, 2009

CONSOLIDATED STATEMENTS OF INCOME

Year ended June 30 (in thousands, except per share data)	2009		2008		2007
Sales	\$	1,999,859	\$	2,589,786	\$ 2,265,336
Cost of goods sold		1,423,320		1,682,715	1,438,137
Gross profit		576,539		907,071	827,199
Operating expense		489,567		594,187	543,952
Restructuring and asset impairment charges (Notes 2 and 16)		173,656		39,891	5,970
Loss on divestitures (Note 4)		-		582	1,686
Amortization of intangibles		13,134		13,864	9,852
Operating (loss) income		(99,818)		258,547	265,739
Interest expense		27,244		31,586	28,999
Other income, net		(14,566)		(2,439)	(8,413)
(Loss) income from continuing operations before income taxes and minority interest expense		(112,496)		229,400	245,153
(Benefit) provision for income taxes (Note 13)		(11,205)		62,754	68,251
Minority interest expense		1,111		2,980	2,185
(Loss) income from continuing operations		(102,402)		163,666	174,717
(Loss) income from discontinued operations (Note 5)		(17,340)		4,109	(474)
Net (loss) income	\$	(119,742)	\$	167,775	\$ 174,243
PER SHARE DATA (Note 2)					
Basic (loss) earnings					
Continuing operations	\$	(1.40)	\$	2.13	\$ 2.28
Discontinued operations		(0.24)		0.05	(0.01)
	\$	(1.64)	\$	2.18	\$ 2.27
Diluted (loss) earnings					
Continuing operations	\$	(1.40)	\$	2.10	\$ 2.22
Discontinued operations		(0.24)		0.05	-
	\$	(1.64)	\$	2.15	\$ 2.22
Dividends per share	\$	0.48	\$	0.47	\$ 0.41
Basic weighted average shares outstanding		73,122		76,811	76,788
Diluted weighted average shares outstanding		73,122		78,201	78,545

The accompanying notes are an integral part of these consolidated financial statements.

CONSOLIDATED BALANCE SHEETS

As of June 30 (in thousands, except per share data)	2009	2008
ASSETS		
Current assets:		
Cash and cash equivalents	\$ 69,823	\$ 86,478
Accounts receivable, less allowance for doubtful accounts of \$25,228 and \$18,473	278,977	512,794
Inventories (Note 9)	381,306	460,800
Deferred income taxes (Note 13)	51,797	53,330
Other current assets	94,001	38,584
Total current assets	875,904	1,151,986
Property, plant and equipment:		
Land and buildings	357,285	375,128
Machinery and equipment	1,322,107	1,382,028
Less accumulated depreciation	(959,066)	(1,007,401)
Property, plant and equipment, net	720,326	749,755
Other assets:		
Investments in affiliated companies	2,138	2,325
Goodwill (Note 2)	502,983	608,519
Intangible assets, less accumulated amortization of \$53,159 and \$42,010 (Note 2)	174,453	194,203
Deferred income taxes (Note 13)	23,129	25,021
Other	48,041	52,540
Total other assets	750,744	882,608
Total assets	\$ 2,346,974	\$ 2,784,349
LIABILITIES		
Current liabilities:		
Current maturities of long-term debt and capital leases (Note 11)	\$ 21,147	\$ 813
Notes payable to banks (Note 12)	28,218	32,787
Accounts payable	87,176	189,050
Accrued income taxes (Note 13)	18,897	28,102
Accrued vacation pay	39,088	40,255
Accrued payroll	42,750	81,384
Other current liabilities (Note 10)	141,693	148,920
Total current liabilities	378,969	521,311
Long-term debt and capital leases, less current maturities (Note 11)	436,592	313,052
Deferred income taxes (Note 13)	71,281	76,980
Accrued postretirement benefits (Note 14)	18,548	23,599
Accrued pension benefits (Note 14)	114,239	105,580
Accrued income taxes (Note 13)	5,497	17,213
Other liabilities	54,393	57,180
Total liabilities	1,079,519	1,114,915
Commitments and contingencies (Note 20)		
Minority interest in consolidated subsidiaries	20,012	21,527
SHAREOWNERS' EQUITY (Notes 2 and 22)		
Preferred stock, no par value; 5,000 shares authorized; none issued	-	-
Capital stock, \$1.25 par value; 120,000 shares authorized; 73,232 and 76,858 shares issued	91,540	96,076
Additional paid-in capital	357,839	468,169
Retained earnings	786,345	941,553
Accumulated other comprehensive income	11,719	142,109
Total shareowners' equity	1,247,443	1,647,907
Total liabilities and shareowners' equity	\$ 2,346,974	\$ 2,784,349

The accompanying notes are an integral part of these consolidated financial statements.

CONSOLIDATED STATEMENTS OF CASH FLOW

Year ended June 30 (in thousands)	2009	2008	2007
OPERATING ACTIVITIES			
Net (loss) income	\$ (119,742)	\$ 167,775	\$ 174,243
Adjustments for non-cash items:			
Depreciation	83,247	80,869	68,811
Amortization	13,134	13,864	9,852
Stock-based compensation expense	9,412	9,512	16,276
Restructuring and asset impairment charges	115,212	39,891	8,970
Loss on divestitures	22,704	582	2,531
Deferred income tax provision	(10,898)	31,967	(8,938)
Other	23	1,945	(1,598)
Changes in certain assets and liabilities, excluding effects of acquisitions and divestitures:			
Accounts receivable	200,159	(14,297)	(31,062)
Inventories	36,048	(34,034)	(26,117)
Accounts payable and accrued liabilities	(118,133)	(4,792)	39,343
Accrued income taxes	(11,969)	(9,734)	(63,516)
Other	(26,934)	(3,762)	10,211
Net cash flow provided by operating activities	192,263	279,786	199,006
INVESTING ACTIVITIES			
Purchases of property, plant and equipment	(104,842)	(163,489)	(92,001)
Disposals of property, plant and equipment	2,914	2,839	3,455
Acquisitions of business assets, net of cash acquired	(69,485)	(2,968)	(246,496)
Proceeds from divestitures (Notes 4 and 5)	1,544	23,229	36,172
Proceeds from sale of investments in affiliated companies	108	5,915	-
Other	(295)	3,233	(3,668)
Net cash flow used for investing activities	(170,056)	(131,241)	(302,538)
FINANCING ACTIVITIES			
Net increase in notes payable	14,311	28,196	2,741
Term debt borrowings	974,248	338,646	43,541
Term debt repayments	(860,522)	(404,904)	(99,576)
Purchase of capital stock	(127,720)	(65,429)	(41,401)
Proceeds from interest rate swap agreement termination (Note 7)	12,566	-	-
Dividend reinvestment and employee benefit and stock plans	4,873	14,811	50,914
Cash dividends paid to shareowners	(35,466)	(35,994)	(31,759)
Other	2,184	(1,031)	(7,181)
Net cash flow used for financing activities	(15,526)	(125,705)	(82,721)
Effect of exchange rate changes on cash and cash equivalents	(23,336)	13,205	2,710
CASH AND CASH EQUIVALENTS			
Net (decrease) increase in cash and cash equivalents	(16,655)	36,045	(183,543)
Cash and cash equivalents, beginning of period	86,478	50,433	233,976
Cash and cash equivalents, end of period	\$ 69,823	\$ 86,478	\$ 50,433

The accompanying notes are an integral part of these consolidated financial statements.

Note: Amounts presented for all years include cash flows from discontinued operations.

CONSOLIDATED STATEMENTS OF SHAREOWNERS' EQUITY

Year ended June 30 (in thousands)	2009		2008		2007	
	Shares	Amount	Shares	Amount	Shares	Amount
CAPITAL STOCK (Note 2)						
Balance at beginning of year	76,858	\$ 96,076	82,974	\$ 103,722	80,712	\$ 100,896
Dividend reinvestment	28	35	13	16	-	-
Capital stock issued under employee benefit and stock plans	346	429	649	806	2,262	2,826
Treasury share restoration (Note 22)	-	-	(6,456)	(8,066)	-	-
Purchase of capital stock	(4,000)	(5,000)	(322)	(402)	-	-
Balance at end of year	73,232	91,540	76,858	96,076	82,974	103,722
ADDITIONAL PAID-IN CAPITAL (Note 2)						
Balance at beginning of year		468,169		655,086		587,951
Dividend reinvestment		569		456		1,643
Capital stock issued under employee benefit and stock plans		11,821		24,362		65,492
Treasury share restoration (Note 22)		-		(202,484)		-
Purchase of capital stock		(122,720)		(9,251)		-
Balance at end of year		357,839		468,169		655,086
RETAINED EARNINGS						
Balance at beginning of year		941,553		812,917		670,433
Net (loss) income		(119,742)		167,775		174,243
Cash dividends paid to shareowners		(35,466)		(35,994)		(31,759)
Impact of adoption of FIN48		-		(3,145)		-
Balance at end of year		786,345		941,553		812,917
TREASURY SHARES, AT COST (Note 2)						
Balance at beginning of year	-	-	(5,002)	(148,932)	(3,498)	(101,781)
Dividend reinvestment	-	-	10	315	266	6,050
Purchase of capital stock	-	-	(1,410)	(55,776)	(1,376)	(41,401)
Capital stock issued under employee benefit and stock plans	-	-	(54)	(6,157)	(394)	(11,800)
Treasury share restoration (Note 22)	-	-	6,456	210,550	-	-
Balance at end of year	-	-	-	-	(5,002)	(148,932)
ACCUMULATED OTHER COMPREHENSIVE INCOME						
Balance at beginning of year		142,109		61,674		37,866
Unrealized (loss) gain on derivatives designated and qualified as cash flow hedges, net of tax		(3,006)		2,412		1,035
Reclassification of unrealized gain (loss) on expired derivatives and qualified as cash flow hedges, net of tax		5,290		(2,452)		(1,682)
Unrecognized net pension and other postretirement benefit losses, net of tax		(14,283)		(21,393)		-
Reclassification of net pension and other postemployment benefit losses, net of tax		1,496		3,249		-
Minimum pension liability adjustment, net of tax		-		-		8,348
Foreign currency translation adjustments, net of tax		(119,887)		98,619		46,739
Other comprehensive (loss) income, net of tax		(130,390)		80,435		54,440
Impact of adoption of SFAS 158, net of tax		-		-		(30,632)
Balance at end of year		11,719		142,109		61,674
Total shareowners' equity, June 30		\$ 1,247,443		\$ 1,647,907		\$ 1,484,467

The accompanying notes are an integral part of these consolidated financial statements.

NOTES TO CONSOLIDATED FINANCIAL STATEMENTS

NOTE 1 - NATURE OF OPERATIONS

Kennametal Inc. is a leading global supplier of tooling, engineered components and advanced materials consumed in production processes. We believe that our reputation for manufacturing excellence as well as our technological expertise and innovation in our principal products has helped us achieve a leading market presence in our primary markets. End users of our products include metalworking manufacturers and suppliers across a diverse array of industries including the aerospace, automotive, machine tool, light machinery and heavy machinery industries, as well as manufacturers, producers and suppliers in a number of other industries including coal mining, highway construction, quarrying and oil and gas exploration and production industries. Our end users' products include items ranging from airframes to coal, medical implants to oil wells and turbochargers to motorcycle parts.

Unless otherwise specified, any reference to a "year" is to a fiscal year ended June 30. When used in this annual report on Form 10-K, unless the context requires otherwise, the terms "we," "our" and "us" refer to Kennametal Inc. and its subsidiaries.

NOTE 2 - SUMMARY OF SIGNIFICANT ACCOUNTING POLICIES

The summary of our significant accounting policies is presented below to assist in evaluating our consolidated financial statements.

PRINCIPLES OF CONSOLIDATION The consolidated financial statements include our accounts and those of our majority-owned subsidiaries. All significant intercompany balances and transactions are eliminated. Investments in entities of less than 50 percent of the voting stock over which we have significant influence are accounted for on an equity basis. The factors used to determine significant influence include, but are not limited to, our management involvement in the investee, such as hiring and setting compensation for management of the investee, the ability to make operating and capital decisions of the investee, representation on the investee's board of directors and purchase and supply agreements with the investee. Investments in entities of less than 50 percent of the voting stock in which we do not have significant influence are accounted for on the cost basis.

USE OF ESTIMATES IN THE PREPARATION OF FINANCIAL STATEMENTS In preparing our consolidated financial statements in conformity with accounting principles generally accepted in the United States of America, we make judgments and estimates about the amounts reflected in our financial statements. As part of our financial reporting process, our management collaborates to determine the necessary information on which to base our judgments and develop estimates used to prepare the financial statements. We use historical experience and available information to make these judgments and estimates. However, different amounts could be reported using different assumptions and in light of different facts and circumstances. Therefore, actual amounts could differ from the estimates reflected in our financial statements.

CAPITAL STOCK SPLIT On October 23, 2007, the Board of Directors approved a two-for-one capital stock split in the form of a capital stock dividend, which was distributed after the close of trading on December 18, 2007 to all shareowners of record as of the close of business on December 4, 2007. The stated par value of each share was not changed from \$1.25. The related issuance of 41.7 million additional shares resulted in a \$52.1 million transfer from additional paid-in-capital to capital stock. All share and per share amounts as well as the balance sheet accounts for capital stock and additional paid-in capital in these consolidated financial statements retroactively reflect the effect of this capital stock split.

CASH AND CASH EQUIVALENTS Cash investments having original maturities of three months or less are considered cash equivalents. Cash equivalents principally consist of investments in money market funds and bank deposits at June 30, 2009.

ACCOUNTS RECEIVABLE We market our products to a diverse customer base throughout the world. Trade credit is extended based upon periodically updated evaluations of each customer's ability to satisfy its obligations. We make judgments as to our ability to collect outstanding receivables and provide allowances for the portion of receivables when collection becomes doubtful. Accounts receivable reserves are determined based upon an aging of accounts and a review of specific accounts.

INVENTORIES Inventories are stated at the lower of cost or market. We use the last-in, first-out (LIFO) method for determining the cost of a significant portion of our United States (U.S.) inventories. The cost of the remainder of our inventories is determined under the first-in, first-out or average cost methods. When market conditions indicate an excess of carrying costs over market value, a lower-of-cost-or-market provision is recorded. Excess and obsolete inventory reserves are established based upon our evaluation of the quantity of inventory on hand relative to demand. The excess and obsolete inventory reserve at June 30, 2009 and 2008 was \$61.1 million and \$61.5 million, respectively.

PROPERTY, PLANT AND EQUIPMENT Property, plant and equipment are carried at cost. Major improvements are capitalized, while maintenance and repairs are expensed as incurred. Retirements and disposals are removed from cost and accumulated depreciation accounts, with the gain or loss reflected in operating income. Interest related to the construction of major facilities is capitalized as part of the construction costs and is amortized over the facilities estimated useful life.

Depreciation for financial reporting purposes is computed using the straight-line method over the following estimated useful lives: building and improvements over 15-40 years; machinery and equipment over 4-15 years; furniture and fixtures over 5-10 years and computer hardware and software over 3-5 years.

Leased property and equipment under capital leases are amortized using the straight-line method over the terms of the related leases.

LONG-LIVED ASSETS We evaluate the recoverability of property, plant and equipment and intangible assets that are amortized whenever events or changes in circumstances indicate the carrying amount of any such assets may not be fully recoverable. Changes in circumstances include technological advances, changes in our business model, capital structure, economic conditions or operating performance. Our evaluation is based upon, among other things, our assumptions about the estimated future undiscounted cash flows these assets are expected to generate. When the sum of the undiscounted cash flows is less than the carrying value, we will recognize an impairment loss to the extent that carrying value exceeds fair value. We apply our best judgment when performing these evaluations to determine if a triggering event has occurred, the undiscounted cash flows used to assess recoverability and the fair value of the asset.

GOODWILL AND INTANGIBLE ASSETS Goodwill represents the excess of cost over the fair value of the net assets of acquired companies. Goodwill and intangible assets with indefinite lives are tested at least annually for impairment. We perform our annual impairment tests during the June quarter in connection with our annual planning process unless there are impairment indicators that warrant a test prior to that.

The carrying amount of goodwill attributable to each segment at June 30 is as follows:

(in thousands)	2008	Acquisitions/ Divestitures	Impairment	Adjustments	Translation	2009
MSSG	\$ 282,187	\$ (3,851)	\$ -	\$ -	\$ (15,396)	\$ 262,940
AMSG	326,332	21,461	(100,168)	-	(7,582)	240,043
Total	\$ 608,519	\$ 17,610	\$ (100,168)	\$ -	\$ (22,978)	\$ 502,983

(in thousands)	2007	Acquisitions/ Divestitures	Impairment	Adjustments	Translation	2008
MSSG	\$ 282,670	\$ (4,394)	\$ -	\$ (12,058)	\$ 15,969	\$ 282,187
AMSG	348,693	-	(35,000)	6,196	6,443	326,332
Total	\$ 631,363	\$ (4,394)	\$ (35,000)	\$ (5,862)	\$ 22,412	\$ 608,519

During 2009, we acquired Tricon which generated additional AMSG goodwill of \$21.5 million. Within MSSG, we made a small acquisition in 2009 which resulted in additional MSSG goodwill of \$1.9 million. Also during 2009, we divested HSS which resulted in a reduction to MSSG goodwill of \$5.8 million.

In the process of preparing our interim financial statements for the March 2009 quarter, we determined that the magnitude and duration of the economic downturn, as well as other factors, served as a triggering event for an impairment test of our surface finishing machines and services business as well as our engineered products business. These businesses are both part of our AMSG segment. As a result of our test, we recorded a goodwill impairment charge of \$100.2 million. Of this amount, \$37.3 million related to our surface finishing machines and services business and \$62.9 million related to our engineered products business. No goodwill remains on the books for our surface finishing machines and services business.

During 2008, we completed purchase price allocations for two 2008 acquisitions resulting in additional MSSG goodwill of \$1.1 million. We also completed the divestitures of two MSSG non-core businesses that resulted in a reduction in MSSG goodwill of \$5.5 million.

We also recorded a goodwill impairment charge of \$35.0 million during 2008 for our surface finishing machines and services business. The change was recorded as a result of a revised earnings forecast for the business due to a decline in operating performance and market weakness.

During 2008, we completed purchase price allocations for three 2007 acquisitions resulting in a \$9.6 million reduction in MSSG goodwill and a \$6.2 million increase in AMSG goodwill. In 2008, we released a deferred tax valuation allowance of \$2.5 million, which was established as a result of the acquisition of the Widia Group in 2003, and recognized a corresponding reduction in MSSG goodwill.

The components of our intangible assets were as follows as of June 30:

(in thousands)	Estimated Useful Life (in years)	2009		2008	
		Gross Carrying Amount	Accumulated Amortization	Gross Carrying Amount	Accumulated Amortization
Contract-based	4 to 15	\$ 6,357	\$ (4,896)	\$ 6,237	\$ (4,469)
Technology-based and other	4 to 15	39,472	(18,971)	41,461	(16,850)
Customer-related	10 to 20	111,687	(22,773)	109,387	(16,233)
Unpatented technology	30	19,484	(3,802)	19,725	(2,955)
Trademarks	5 to 20	10,782	(2,717)	5,788	(1,503)
Trademarks	Indefinite	39,830	-	53,615	-
Total		\$ 227,612	\$ (53,159)	\$ 236,213	\$ (42,010)

As a result of the 2009 business acquisitions referred to above, we recorded \$11.8 million of identifiable intangible assets: Contract-based increased \$0.2 million, Customer-related increased \$6.3 million, Trademarks increased \$5.1 million and Technology-based and other increased \$0.2 million. As a result of the impairment test performed in 2009, we also recorded a \$10.8 million impairment charge for the indefinite-lived trademark for our surface finishing machines and services business. Also during 2009, foreign currency effects contributed to a decrease of \$7.7 million in net intangible assets and we recorded \$13.1 million in amortization expense.

In 2008, we completed purchase price allocations for three 2007 acquisitions and two 2008 acquisitions. As a result, Technology-based and other decreased \$10.6 million, Customer-related increased \$9.2 million, Contract-based decreased \$1.2 million and Trademarks decreased \$1.1 million. The 2008 divestiture of two non-core businesses resulted in a \$1.5 million reduction in Customer-related intangible assets. Also during 2008, foreign currency effects contributed to an increase of \$10.1 million in net intangible assets and we recorded \$13.9 million in amortization expense.

We continue to review our marketing strategies related to all of our brands. During 2007, we completed our strategic analysis and plan for our Widia brand. As a key element of our channel and brand strategy, we decided to leverage the strength of this brand to accelerate growth in the distribution market. Since demand in the distribution market is mostly for standard products and to further our relationship with our Widia distributors, we furthermore decided to migrate direct sales of Widia custom solutions products to the Kennametal brand. As a result and in accordance with SFAS No. 142, "Goodwill and Other Intangible Assets," we recorded a \$6.0 million asset impairment charge related to our MSSG Widia trademark.

Amortization expense for intangible assets was \$13.1 million, \$13.9 million and \$9.9 million for 2009, 2008 and 2007, respectively. Estimated amortization expense for 2010 through 2014 is \$12.8 million, \$11.7 million, \$11.0 million, \$10.3 million and \$10.0 million, respectively.

PENSION AND OTHER POSTRETIREMENT AND POSTEMPLOYMENT BENEFITS We sponsor these types of benefit plans for a majority of our employees and retirees. Accounting for the cost of these plans requires the estimation of the cost of the benefits to be provided well into the future and attributing that cost over the expected work life of employees participating in these plans. This estimation requires our judgment about the discount rate used to determine these obligations, expected return on plan assets, rate of future compensation increases, rate of future health care costs, withdrawal and mortality rates and participant retirement age. Differences between our estimates and actual results may significantly affect the cost of our obligations under these plans.

In the valuation of our pension and other postretirement and postemployment benefit liabilities, management utilizes various assumptions. We determine our discount rate based on investment grade bond yield curves with a duration that approximates the benefit payment timing of each plan. This rate can fluctuate based on changes in investment grade bond yields.

The long-term rate of return on plan assets is estimated based on an evaluation of historical returns for each asset category held by the plans, coupled with the current and short-term mix of the investment portfolio. The historical returns are adjusted for expected future market and economic changes. This return will fluctuate based on actual market returns and other economic factors.

The rate of future health care costs is based on historical claims and enrollment information projected over the next year and adjusted for administrative charges. This rate is expected to decrease until 2029.

Future compensation rates, withdrawal rates and participant retirement age are determined based on historical information. These assumptions are not expected to significantly change. Mortality rates are determined based on a review of published mortality tables.

DEFERRED FINANCING FEES Fees incurred in connection with new borrowings are capitalized and amortized to interest expense over the life of the related obligation.

EARNINGS PER SHARE Basic earnings per share is computed using the weighted average number of shares outstanding during the period, while diluted earnings per share is calculated to reflect the potential dilution that occurs related to issuance of capital stock under stock option grants and restricted stock awards. The difference between basic and diluted earnings per share relates solely to the effect of capital stock options and restricted stock awards.

For 2009, the effect of unexercised capital stock options and restricted stock awards was anti-dilutive and therefore has been excluded from diluted shares outstanding as well as from the diluted earnings per share calculation. For purposes of determining the number of diluted shares outstanding at June 30, 2008 and 2007, weighted average shares outstanding for basic earnings per share calculations were increased due solely to the dilutive effect of unexercised capital stock options and restricted stock awards by 1.4 million shares and 1.8 million shares, respectively. Unexercised capital stock options of 2.6 million, 0.5 million and 0.5 million shares at June 30, 2009, 2008 and 2007, respectively, were not included in the computation of diluted earnings per share because the option exercise price was greater than the average market price, and therefore their inclusion would have been anti-dilutive. See disclosure of our 2008 capital stock split within this note.

REVENUE RECOGNITION We recognize revenue upon shipment of our products and assembled machines. Our general conditions of sale explicitly state that the delivery of our products and assembled machines is F.O.B. shipping point and that title and all risks of loss and damage pass to the buyer upon delivery of the sold products or assembled machines to the common carrier.

Our general conditions of sale explicitly state that acceptance of the conditions of shipment are considered to have occurred unless written notice of objection is received by Kennametal within 10 calendar days of the date specified on the invoice. We do not ship products or assembled machines unless we have documentation from our customers authorizing shipment. Our products are consumed by our customers in the manufacture of their products. Historically, we have experienced very low levels of returned products and assembled machines and do not consider the effect of returned products and assembled machines to be material. We have recorded an estimated returned goods allowance to provide for any potential returns.

We warrant that products and services sold are free from defects in material and workmanship under normal use and service when correctly installed, used and maintained. This warranty terminates 30 days after delivery of the product to the customer, and does not apply to products that have been subjected to misuse, abuse, neglect or improper storage, handling or maintenance. Products may be returned to Kennametal, only after inspection and approval by Kennametal and upon receipt by the customer of shipping instructions from Kennametal. We have included an estimated allowance for warranty returns in our returned goods allowance discussed above.

We recognize revenue related to the sale of specialized assembled machines upon customer acceptance and installation, as installation is deemed essential to the functionality of a specialized assembled machine. Sales of specialized assembled machines were immaterial for 2009, 2008 and 2007.

STOCK-BASED COMPENSATION We recognize stock-based compensation expense for all stock options, restricted stock awards and restricted stock units over the period from the date of grant to the date when the award is no longer contingent on the employee providing additional service (substantive vesting period). We continue to follow the nominal vesting period approach for unvested awards granted prior to our adoption of SFAS No. 123(R), "Share-Based Payment (revised 2004)" (SFAS 123(R)) on July 1, 2005. We utilize the Black-Scholes valuation method to establish the fair value of all awards.

Capital stock options are granted to eligible employees at fair market value at the date of grant. Capital stock options are exercisable under specified conditions for up to 10 years from the date of grant. The aggregate number of shares available for issuance under the Kennametal Inc. Stock and Incentive Plan of 2002, as amended (2002 Plan) is 9,000,000. See disclosure of our 2008 capital stock split within this note. Under the provisions of the 2002 Plan, participants may deliver our stock, owned by the holder for at least six months, in payment of the option price and receive credit for the fair market value of the shares on the date of delivery. The fair value of shares delivered during 2009 was \$0.7 million. In addition to stock option grants, the 2002 Plan permits the award of restricted stock to directors, officers and key employees.

RESEARCH AND DEVELOPMENT COSTS Research and development costs of \$27.6 million, \$32.6 million and \$28.8 million in 2009, 2008 and 2007, respectively, were expensed as incurred. These costs are included in operating expense in the consolidated statements of income.

SHIPPING AND HANDLING FEES AND COSTS All fees billed to customers for shipping and handling are classified as a component of net sales. All costs associated with shipping and handling are classified as a component of cost of goods sold.

INCOME TAXES Deferred income taxes are recognized based on the future income tax effects (using enacted tax laws and rates) of differences in the carrying amounts of assets and liabilities for financial reporting and tax purposes. A valuation allowance is recognized if it is “more likely than not” that some or all of a deferred tax asset will not be realized.

DERIVATIVE INSTRUMENTS AND HEDGING ACTIVITIES As part of our financial risk management program, we use certain derivative financial instruments. We do not enter into derivative transactions for speculative purposes and therefore hold no derivative instruments for trading purposes. We use derivative financial instruments to provide predictability to the effects of changes in foreign exchange rates on our consolidated results and to achieve our targeted mix of fixed and floating interest rates on outstanding debt. Our objective in managing foreign exchange exposures with derivative instruments is to reduce volatility in cash flow, allowing us to focus more of our attention on business operations. With respect to interest rate management, these derivative instruments allow us to achieve our targeted fixed-to-floating interest rate mix as a separate decision from funding arrangements in the bank and public debt markets.

We account for derivative instruments as a hedge of the related asset, liability, firm commitment or anticipated transaction when the derivative is specifically designated as a hedge of such items. We measure hedge effectiveness by assessing the changes in the fair value or expected future cash flows of the hedged item. The ineffective portions are recorded in other income, net.

Certain currency forward contracts hedging significant cross-border intercompany loans are considered other derivatives and therefore do not qualify for hedge accounting. These contracts are recorded at fair value in the balance sheet, with the offset to other income, net.

CASH FLOW HEDGES *Currency* Forward contracts and range forward contracts (a transaction where both a put option is purchased and a call option is sold), designated as cash flow hedges, hedge anticipated cash flows from cross-border intercompany sales of products and services. Gains and losses realized on these contracts at maturity are recorded in accumulated other comprehensive income (loss), net of tax, and are recognized as a component of other income, net when the underlying sale of products or services are recognized into earnings. The notional amount of the contracts translated into U.S. dollars at June 30, 2009 and 2008, were \$1.7 million and \$126.5 million, respectively. The time value component of the fair value of range forwards is excluded from the assessment of hedge effectiveness. Assuming the market rates remain constant with the rates at June 30, 2009, we expect to recognize into earnings in the next 12 months gains on outstanding derivatives of \$1.2 million.

Floating-to-fixed interest rate swap agreements, designated as cash flow hedges, are entered into from time to time to hedge our exposure to interest rate changes on a portion of our floating rate debt. These interest rate swap agreements convert a portion of our floating rate debt to fixed rate debt. We record the fair value of these contracts as an asset or a liability, as applicable, in the balance sheet, with the offset to accumulated other comprehensive income (loss), net of tax. We had no such agreements outstanding at June 30, 2009 and 2008.

FAIR VALUE HEDGES Fixed-to-floating interest rate swap agreements, designated as fair value hedges, are entered into from time to time to hedge our exposure to fair value fluctuations on a portion of our fixed rate debt. These interest rate swap agreements convert a portion of our fixed rate debt to floating rate debt. When in place, these agreements require periodic settlement and the difference between amounts to be received and paid under the agreements is recognized in interest expense. As of June 30, 2009, there were no gains or losses related to these contracts. As of June 30, 2008, we recorded a gain of \$0.7 million related to these contracts. We record the gain or loss on these contracts as an asset or a liability, as applicable, in the balance sheet, with the offset to the carrying value of the debt. Any gain or loss resulting from changes in the fair value of these contracts offset the corresponding gains or losses from changes in the fair values of the debt. As a result, changes in the fair value of these contracts have no net impact on current period earnings.

In February 2009, we terminated interest rate swap agreements to convert \$200 million of our fixed rate debt to floating rate debt. These agreements were originally set to mature in June 2012. Upon termination, we received a cash payment of \$13.2 million. Within the consolidated statement of cash flow for the year ended June 30, 2009, \$12.6 million forward portion of the payment has been disclosed under cash flow used for financing activities and the \$0.6 million current interest portion has been disclosed under cash flow provided by operating activities. This gain is being amortized as a component of interest expense over the remaining term of the related debt using the effective interest rate method. During the year ended June 30, 2009, \$3.2 million was recognized as a reduction in interest expense.

FOREIGN CURRENCY TRANSLATION Assets and liabilities of international operations are translated into U.S. dollars using year-end exchange rates, while revenues and expenses are translated at average exchange rates throughout the year. The resulting net translation adjustments are recorded as a component of accumulated other comprehensive income (loss). The local currency is the functional currency of most of our locations. Gains from foreign currency transactions included in other income, net were \$6.8 million for 2009, and losses from foreign currency transactions included in other income, net were \$6.4 million and \$1.7 million for 2008 and 2007, respectively.

NEW ACCOUNTING STANDARDS On June 30, 2009, Kennametal adopted SFAS No. 165, "Subsequent Events," (SFAS 165). SFAS 165 establishes general standards of accounting for and disclosure of events that occur after the balance sheet date but before financial statements are issued or are available to be issued. Specifically, SFAS 165 sets forth the period after the balance sheet date during which management of a reporting entity should evaluate events or transactions that may occur for potential recognition or disclosure in the financial statements, the circumstances under which an entity should recognize events or transactions occurring after the balance sheet date in its financial statements, and the disclosures that an entity should make about events or transactions that occurred after the balance sheet date. See Note 24 for additional disclosures.

On June 30, 2009, Kennametal adopted FSP No. FAS 157-4, "Determining Fair Value When the Volume and Level of Activity for the Asset or Liability Have Significantly Decreased and Identifying Transactions That Are Not Orderly" (FSP 157-4). FSP 157-4 provides guidance on factors to be considered while estimating fair value in accordance with SFAS No. 157, "Fair Value Measurements" (SFAS 157), when there has been a significant decrease in market activity for an asset or liability. This guidance retains the existing "exit price" concept under SFAS 157 and therefore does not change the objective of fair value measurements, even when there has been a significant decrease in market activity. The adoption of FSP 157-4 did not have an impact on our consolidated financial statements.

In June 2009, the FASB issued SFAS No. 168, "The FASB Accounting Standards Codification and the Hierarchy of Generally Accepted Accounting Principles" (SFAS 168). SFAS 168 replaces FASB Statement No. 162, "The Hierarchy of Generally Accepted Accounting Principles." The FASB Accounting Standards Codification (Codification) is the single source of authoritative nongovernmental accounting principles generally accepted in the United States of America (U.S. GAAP). The Codification does not change current U.S. GAAP, but is intended to simplify user access to all authoritative U.S. GAAP by providing all the authoritative literature related to a particular topic in one place. All existing accounting standard documents will be superseded and all other accounting literature not included in the Codification will be considered non-authoritative. SFAS 168 is effective for Kennametal as of September 30, 2009. We are in the process of evaluating the provisions of SFAS 168 to determine the impact of the Codification on our financial reporting process and for providing Codification references in our public filings.

In June 2009, the FASB issued SFAS No. 167, "Amendments to FASB Interpretation No. 46(R)" (SFAS 167). SFAS 167 modifies how a company determines when an entity that is insufficiently capitalized or is not controlled through voting (or similar rights) should be consolidated. SFAS 167 clarifies that the determination of whether a company is required to consolidate an entity is based on, among other things, an entity's purpose and design and a company's ability to direct the activities of the entity that most significantly impact the entity's economic performance. SFAS 167 requires an ongoing reassessment of whether a company is the primary beneficiary of a variable interest entity. SFAS 167 also requires additional disclosures about a company's involvement in variable interest entities and any significant changes in risk exposure due to that involvement. SFAS 167 is effective for Kennametal Inc. beginning July 1, 2010. We are in the process of evaluating the provisions of SFAS 167 to determine the impact of adoption on our consolidated financial statements.

In June 2009, the FASB issued SFAS No. 166, "Accounting for Transfers of Financial Assets — an amendment of FASB Statement No. 140" (SFAS 166). SFAS 166 requires additional information regarding transfers of financial assets, including securitization transactions, and where companies have continuing exposure to the risks related to transferred financial assets. SFAS 166 eliminates the concept of a "qualifying special-purpose entity," changes the requirements for derecognizing financial assets, and requires additional disclosures. SFAS 166 is effective for Kennametal beginning July 1, 2010. We are in the process of evaluating the provisions of SFAS 166 to determine the impact of adoption on our consolidated financial statements.

In April 2009, the FASB issued FSP No. FAS 107-1 and APB 28-1, "Interim Disclosure about Fair Value of Financial Instruments" (FSP 107-1). FSP 107-1 expands the fair value disclosures to interim periods for all financial instruments that are within the scope of SFAS No. 107, "Disclosures about Fair Value of Financial Instruments." This FSP also requires entities to disclose the methods and significant assumptions used to estimate the fair value of financial instruments as well as significant changes in such methods and assumptions from prior periods. FSP 107-1 is effective for Kennametal as of September 30, 2009. We are in the process of evaluating the provisions of this FSP to determine the impact of adoption on our consolidated financial statements.

In April 2009, the FASB issued FSP No. FAS 141(R)-1, "Accounting for Assets Acquired and Liabilities Assumed in a Business Combination That Arise from Contingencies" (FSP 141(R)-1). This FSP amends the guidance in SFAS No. 141 (revised 2007), "Business Combinations" (SFAS 141(R)) and establishes a model to account for preacquisition contingencies. Under this FSP, an acquirer is required to recognize at fair value an asset or liability assumed in a business combination that arises from a contingency if the acquisition-date fair value can be determined during the measurement period. If the acquisition-date fair value cannot be determined, then the acquirer should follow the recognition criteria in SFAS No. 5, "Accounting for Contingencies" and FASB Interpretation No. 14, "Reasonable Estimation of the Amount of a Loss – an interpretation of FASB Statement No. 5," to determine whether the contingency should be recognized as of the acquisition date or after it. FSP 141(R)-1 is effective for Kennametal beginning July 1, 2009. We are in the process of evaluating the provisions of this FSP to determine the impact of adoption on our consolidated financial statements.

On January 1, 2009, Kennametal adopted SFAS No. 161, "Disclosures about Derivative Instruments and Hedging Activities—an amendment of FASB Statement No. 133" (SFAS 161) as it relates to derivatives and hedging activities. SFAS 161 expands the current disclosure requirements in SFAS No. 133, "Accounting for Derivative Instruments and Hedging Activities" (SFAS 133) and provides for an enhanced understanding of (1) how and why an entity uses derivative instruments, (2) how derivative instruments and related hedged items are accounted for under SFAS 133 and its related interpretations, and (3) how derivative instruments and related hedged items affect an entity's financial position, financial performance, and cash flows. See Note 7 for additional disclosures.

In December 2008, the FASB issued FSP No. 132(R)-1, "Employers' Disclosures about Postretirement Benefit Plan Assets" (FSP 132(R)-1). FSP 132(R)-1 expands the current disclosure requirements in SFAS No. 132(R), "Employers' Disclosures about Pensions and Other Postretirement Benefits." FSP 132(R)-1 requires companies to disclose how investment allocation decisions are made by management, major categories of plan assets, significant concentrations of risk within plan assets and information about the valuation of plan assets. FSP 132(R)-1 is effective for Kennametal beginning July 1, 2009. We are in the process of evaluating the provisions of this FSP to determine the impact of adoption on our consolidated financial statements.

In November 2008, the FASB ratified EITF Issue No. 08-7, "Accounting for Defensive Intangible Assets" (EITF 08-7). EITF 08-7 applies to all acquired intangible assets in situations in which the entity does not intend to actively use the asset but intends to hold the asset to prevent others from obtaining access to the asset with limited exceptions. EITF 08-7 requires that defensive intangible assets be accounted for as a separate unit of accounting and be assigned a useful life. EITF 08-7 is to be applied prospectively and is effective for Kennametal beginning July 1, 2009. We are in the process of evaluating the provisions of this EITF to determine the impact of adoption on our consolidated financial statements.

In November 2008, the FASB ratified EITF Issue No. 08-6, "Equity Method Investment Accounting Considerations" (EITF 08-6). EITF 08-6 addresses a number of matters associated with the impact that SFAS 141(R) and SFAS No. 160, "Noncontrolling Interest in Consolidated Financial Statements, an amendment of ARB No. 51" (SFAS 160) might have on the accounting for equity method investments. EITF 08-6 provides guidance on how an equity method investment should initially be measured, how it should be tested for impairment and how changes in classification from equity method to cost method should be treated as well as other issues. EITF 08-6 is to be applied prospectively and is effective for Kennametal beginning July 1, 2009. We are in the process of evaluating the provisions of this EITF to determine the impact of adoption on our consolidated financial statements.

On July 1, 2008, Kennametal adopted SFAS No. 159, "The Fair Value Option for Financial Assets and Financial Liabilities—Including an amendment of FASB Statement No. 115" (SFAS 159). SFAS 159 permits entities to choose to measure many financial instruments and certain other assets and liabilities at fair value on an instrument-by-instrument basis (the fair value option) with changes in fair value recognized in earnings at each subsequent reporting date. Kennametal records derivative contracts and hedging activities at fair value in accordance with SFAS 133. The adoption of SFAS 159 therefore had no impact on our consolidated financial statements as management did not elect the fair value option for any other financial instruments or certain other assets and liabilities.

On July 1, 2008, Kennametal adopted SFAS No. 157, "Fair Value Measurements" (SFAS 157) as it relates to financial assets and financial liabilities. In February 2008, the FASB issued FSP No. FAS 157-2, "Effective Date of FASB Statement No. 157," which delayed the effective date of SFAS 157 for all nonfinancial assets and nonfinancial liabilities, except those that are recognized or disclosed at fair value in the financial statements on at least an annual basis, until July 1, 2009 for Kennametal. See Note 6 for additional disclosures.

On July 1, 2008, Kennametal adopted EITF Issue No. 06-11, "Accounting for Income Tax Benefits of Dividends on Share-Based Payment Awards" (EITF 06-11). EITF 06-11 requires that tax benefits generated by dividends paid during the vesting period on certain equity-classified share-based compensation awards be classified as additional paid-in capital and included in a pool of excess tax benefits available to absorb tax deficiencies from share-based payment awards. The adoption of this EITF did not have a material impact on our consolidated financial statements.

In June 2008, the FASB issued FSP No. EITF 03-6-1, "Determining Whether Instruments Granted in Share-Based Payment Transactions Are Participating Securities," (FSP EITF 03-6-1). FSP EITF 03-6-1 states that unvested share-based payment awards that contain nonforfeitable rights to dividends or dividend equivalents (whether paid or unpaid) are participating securities and shall be included in the computation of earnings per share pursuant to the two-class method. FSP EITF 03-6-1 becomes effective for Kennametal on July 1, 2009. Management has determined that the adoption of FSP EITF 03-6-1 will not have a material impact on our consolidated financial statements.

In December 2007, the FASB issued SFAS No. 141(R), "Business Combinations" (SFAS 141(R)) which establishes principles and requirements for how an acquirer accounts for business combinations and includes guidance for the recognition, measurement and disclosure of the identifiable assets acquired, the liabilities assumed and any noncontrolling or minority interest in the acquiree. It also provides guidance for the measurement of goodwill, the recognition of contingent consideration and the accounting for pre-acquisition gain and loss contingencies, as well as acquisition-related transaction costs and the recognition of changes in the acquirer's income tax valuation allowance. SFAS 141(R) is to be applied prospectively and is effective for Kennametal beginning July 1, 2009. We are in the process of evaluating the provisions of SFAS 141(R) to determine the impact of adoption on our consolidated financial statements.

In December 2007, the FASB issued SFAS No. 160, "Noncontrolling Interests in Consolidated Financial Statements" (SFAS 160) which amends Accounting Research Bulletin No. 51, "Consolidated Financial Statements" to establish accounting and reporting standards for any noncontrolling interest in a subsidiary and for the deconsolidation of a subsidiary. SFAS 160 clarifies that a noncontrolling interest in a subsidiary should be reported as a component of equity in the consolidated financial statements and requires disclosure on the face of the consolidated statement of income of the amounts of consolidated net income attributable to the parent and to the noncontrolled interest. SFAS 160 is to be applied prospectively and is effective for Kennametal as of July 1, 2009, except for the presentation and disclosure requirements, which, upon adoption, will be applied retrospectively for all periods presented. We are in the process of evaluating the provisions of SFAS 160 to determine the impact of adoption on our consolidated financial statements.

NOTE 3 – SUPPLEMENTAL CASH FLOW INFORMATION

Year Ended June 30, (in thousands)	2009	2008	2007
Cash paid during the period for:			
Interest	\$ 26,328	\$ 30,648	\$ 27,875
Income taxes	18,020	38,699	127,468
Supplemental disclosure of non-cash information:			
Contribution of stock to employees' defined contribution benefit plans	1,738	-	5,579
Change in fair value of interest rate swaps	730	(11,557)	(3,348)
Changes in accounts payable related to purchases of property, plant and equipment	(12,800)	(1,700)	6,400

NOTE 4 - ACQUISITIONS AND DIVESTITURES

Effective October 1, 2008, we acquired Tricon for a net purchase price of \$64.1 million. As part of our AMMSG segment, we acquired Tricon to expand our products and solutions in the surface and underground mining markets, including hard rock and coal. During 2009, we also made a small acquisition within our MSSG segment. Also during 2009, we made final payments for two small MSSG acquisitions that we made in Europe during 2008.

During 2008, we did not complete any material acquisitions or divestitures. However, we made two small acquisitions in Europe, both within our MSSG segment. Also during 2008, we divested two small, non-core businesses from our MSSG segment, one in the U.S. and one in Europe. Combined cash proceeds received were \$20.2 million and we recognized a combined loss on divestiture of \$0.6 million.

During 2007, we made five acquisitions. Three of these acquisitions were within our AMMSG segment and two were within our MSSG segment.

Also during 2007, we received the remaining cash proceeds of \$9.7 million from our 2006 divestiture of J&L Industrial Supply and recorded a pre-tax loss of \$1.6 million for a related post-closing adjustment.

NOTE 5 – DISCONTINUED OPERATIONS

Effective June 30, 2009, we divested HSS from our MSSG segment as part of our continuing focus to shape our business portfolio and rationalize our manufacturing footprint. This divestiture was accounted for as discontinued operations. The net assets disposed of as a result of this transaction had a net book value of approximately \$51 million and consisted primarily of inventory and equipment, as well as owned and leased facilities. Cash proceeds from this divestiture were \$29 million, of which \$2 million was received prior to closing and \$24 million was received in July 2009. We expect to receive the remaining \$3 million in proceeds in the December 2009 quarter. For 2009, this divested business generated sales of \$81 million and essentially breakeven results. The pre-tax loss on this sale and related pre-tax charges of \$25.5 million as well as the related tax effects, were recorded in discontinued operations in 2009. We expect to incur additional pre-tax charges related to this divestiture of \$4.0 million to \$7.0 million in 2010.

During 2007, we completed the divestiture of our electronics (Electronics) and consumer retail products (CPG) businesses. These divestitures were recorded as discontinued operations. During 2008 and 2007, we received cash proceeds related to the CPG divestiture of \$3.0 million and \$26.5 million, respectively. During 2007, we recorded a combined pre-tax charge related to these divestitures of \$3.9 million.

The following represents the results of discontinued operations for the years ended June 30:

(in thousands)	2009	2008	2007
Sales	\$ 80,630	\$ 115,343	\$ 135,191
(Loss) income from discontinued operations before income taxes	\$ (25,923)	\$ 5,412	\$ 1,879
Income tax (benefit) expense	(8,583)	1,303	2,353
(Loss) income from discontinued operations	\$ (17,340)	\$ 4,109	\$ (474)

NOTE 6 - FAIR VALUE MEASUREMENTS

SFAS 157 defines fair value, establishes a framework for measuring fair value in generally accepted accounting principles (GAAP) and expands disclosures related to fair value measurements. The provisions of this standard apply to other accounting pronouncements that require or permit fair value measurements and are to be applied prospectively with limited exceptions. We are in the process of evaluating the potential impact of SFAS 157, as it relates to pension plan assets, nonfinancial assets and nonfinancial liabilities, on our consolidated financial statements.

SFAS 157 defines fair value as the price that would be received to sell an asset or paid to transfer a liability in an orderly transaction between market participants at the measurement date. This standard is now the single source in GAAP for the definition of fair value, except for the fair value of leased property as defined in SFAS No. 13, "Accounting for Leases." SFAS 157 established a fair value hierarchy that distinguishes between (1) market participant assumptions developed based on market data obtained from independent sources (observable inputs) and (2) an entity's own assumptions about market participant assumptions developed based on the best information available in the circumstances (unobservable inputs). The fair value hierarchy consists of three broad levels, which gives the highest priority to unadjusted quoted prices in active markets for identical assets or liabilities (Level 1) and the lowest priority to unobservable inputs (Level 3). Fair value measurements are assigned a level within the hierarchy based on the lowest significant input level. The three levels of the fair value hierarchy under SFAS 157 are described below:

Level 1: Unadjusted quoted prices in active markets that are accessible at the measurement date for identical, unrestricted assets or liabilities.

Level 2: Inputs other than quoted prices included within Level 1 that are observable for the asset or liability, either directly or indirectly, including quoted prices for similar assets or liabilities in active markets; quoted prices for identical or similar assets or liabilities in markets that are not active; inputs other than quoted prices that are observable for the asset or liability (e.g., interest rates); and inputs that are derived principally from or corroborated by observable market data by correlation or other means.

Level 3: Inputs that are unobservable.

As of June 30, 2009 the fair values of the Company's financial assets and financial liabilities measured at fair value on a recurring basis are categorized as follows:

(in thousands)	Level 1		Level 2		Level 3		Total
Assets:							
Current assets:							
Derivative contracts ^a	\$	-	\$	195	\$	-	\$ 195
Total assets	\$	-	\$	195	\$	-	\$ 195
Current liabilities:							
Derivative contracts ^a	\$	-	\$	36	\$	-	\$ 36

^a Foreign currency derivative contracts are valued based on observable market spot and forward rates and are classified within Level 2 of the fair value hierarchy.

NOTE 7 - DERIVATIVE INSTRUMENTS AND HEDGING ACTIVITIES

As part of our financial risk management program, we use certain derivative financial instruments. We do not enter into derivative transactions for speculative purposes and therefore hold no derivative instruments for trading purposes. We use derivative financial instruments to provide predictability to the effects of changes in foreign exchange rates on our consolidated results and to achieve our targeted mix of fixed and floating interest rates on outstanding debt. We account for derivative instruments as a hedge of the related asset, liability, firm commitment or anticipated transaction when the derivative is specifically designated as a hedge of such items. Our objective in managing foreign exchange exposures with derivative instruments is to reduce volatility in cash flow, allowing us to focus more of our attention on business operations. With respect to interest rate management, these derivative instruments allow us to achieve our targeted fixed-to-floating interest rate mix as a separate decision from funding arrangements in the bank and public debt markets. We measure hedge effectiveness by assessing the changes in the fair value or expected future cash flows of the hedged item. The ineffective portions are recorded in other income, net.

The fair value of derivatives designated and not designated as hedging instruments in the consolidated balance sheets at June 30 are as follows:

(in thousands)	2009		2008	
Derivatives designated as hedging instruments				
Other current assets - range forward contracts	\$	182	\$	395
Non current assets - range forward contracts		-		35
Other current liabilities - range forward contracts		-		(720)
Total derivatives designated as hedging instruments		182		(290)
Derivatives not designated as hedging instruments				
Other current assets - currency forward contracts		13		61
Other current liabilities - currency forward contracts		(36)		(4)
Total derivatives not designated as hedging instruments		(23)		57
Total derivatives	\$	159	\$	(233)

Certain currency forward contracts hedging significant cross-border intercompany loans are considered as other derivatives and therefore do not qualify for hedge accounting. These contracts are recorded at fair value in the balance sheet, with the offset to other income, net. The following represents gains (losses) related to derivatives not designated as hedging instruments for the years ended June 30:

(in thousands)	2009		2008	
Other expense (income), net - currency forward contracts	\$	73	\$	(209)

FAIR VALUE HEDGES

Fixed-to-floating interest rate swap agreements, designated as fair value hedges, are entered into from time to time to hedge our exposure to fair value fluctuations on a portion of our fixed rate debt. These interest rate swap agreements convert a portion of our fixed rate debt to floating rate debt. These contracts require periodic settlement and the difference between amounts to be received and paid under the interest rate swap agreements is recognized in interest expense. As of June 30, 2009, there were no gains or losses related to these contracts. As of June 30, 2008 and 2007, we recorded a gain of \$0.7 million and a loss of \$10.8 million, respectively related to these contracts. We record the gain or loss on these contracts as an asset or a liability, as applicable, in the balance sheet, with the offset to the carrying value of the debt. Any gain or loss resulting from changes in the fair value of these contracts offset the corresponding gains or losses from changes in the fair values of the debt. As a result, changes in the fair value of these contracts have no net impact on current period earnings.

In February 2009, we terminated interest rate swap agreements to convert \$200 million of our fixed rate debt to floating rate debt. These agreements were originally set to mature in June 2012. Upon termination, we received a cash payment of \$13.2 million. Within the consolidated statement of cash flow for the year ended June 30, 2009, \$12.6 million forward portion of the payment has been disclosed under cash flow used for financing activities and the \$0.6 million current interest portion has been disclosed under cash flow provided by operating activities. This gain is being amortized as a component of interest expense over the remaining term of the related debt using the effective interest rate method. During the year ended June 30, 2009, \$3.2 million was recognized as a reduction in interest expense.

The following represents gains related to fair value hedges for the years ended June 30:

(in thousands)	2009	2008
Interest expense - interest rate swap agreements	\$ (3,170)	\$ (1,687)

CASH FLOW HEDGES

Currency forward contracts and range forward contracts (a transaction where both a put option is purchased and a call option is sold), designated as cash flow hedges, hedge anticipated cash flows from cross-border intercompany sales of products and services. Gains and losses realized on these contracts at maturity are recorded in accumulated other comprehensive income (loss), net of tax, and are recognized as a component of other income, net when the underlying sale of products or services are recognized into earnings. The notional amount of the contracts translated into U.S. dollars at June 30, 2009 and 2008, were \$1.7 million and \$126.5 million, respectively. The time value component of the fair value of range forwards is excluded from the assessment of hedge effectiveness. Assuming the market rates remain constant with the rates at June 30, 2009, we expect to recognize into earnings in the next 12 months gains on outstanding derivatives of \$1.2 million.

Floating-to-fixed interest rate swap agreements, designated as cash flow hedges, are entered into from time to time to hedge our exposure to interest rate changes on a portion of our floating rate debt. These interest rate swap agreements convert a portion of our floating rate debt to fixed rate debt. We record the fair value of these contracts as an asset or a liability, as applicable, in the balance sheet, with the offset to accumulated other comprehensive income (loss), net of tax. We had no such agreements outstanding at June 30, 2009 and 2008.

The following represents gains (losses) related to cash flow hedges for the years ended June 30:

(in thousands)	2009	2008
Gain (loss) recognized in other comprehensive (loss) income - range forward contracts	\$ 107	\$ (536)
Gain (loss) reclassified from accumulated other comprehensive (loss) income into other (income) expense, net - range forward contracts	\$ 8,505	\$ (4,284)

No portion of the gains (losses) recognized in earnings were due to ineffectiveness and no amounts were excluded from our effectiveness testing for the years ended June 30, 2009 and 2008, respectively.

NOTE 8 - ACCOUNTS RECEIVABLE SECURITIZATION PROGRAM

We previously had an agreement with a financial institution whereby we were permitted to securitize, on a continuous basis, an undivided interest in a specific pool of our domestic trade accounts receivable. Pursuant to this agreement, we, and certain of our domestic subsidiaries, sold our domestic accounts receivable to Kennametal Receivables Corporation, a wholly-owned, bankruptcy-remote subsidiary. This agreement was discontinued in 2008.

NOTE 9 – INVENTORIES

Inventories consisted of the following at June 30:

(in thousands)	2009	2008
Finished goods	\$ 242,276	\$ 288,188
Work in process and powder blends	134,713	176,680
Raw materials and supplies	78,851	75,999
Inventories at current cost	455,840	540,867
Less: LIFO valuation	(74,534)	(80,067)
Total inventories	\$ 381,306	\$ 460,800

We used the LIFO method of valuing our inventories for approximately 49 percent and 48 percent of total inventories at June 30, 2009 and 2008, respectively.

NOTE 10 - OTHER CURRENT LIABILITIES

Other current liabilities consisted of the following at June 30:

(in thousands)	2009	2008
Accrued employee benefits	\$ 30,557	\$ 48,330
Payroll, state and local taxes	12,794	4,687
Accrued restructuring expense (Note 16)	26,962	4,950
Other	71,380	90,953
Total other current liabilities	\$ 141,693	\$ 148,920

NOTE 11 - LONG-TERM DEBT AND CAPITAL LEASES

Long-term debt and capital lease obligations consisted of the following at June 30:

(in thousands)	2009	2008
7.20% Senior Unsecured Notes due 2012 net of discount of \$0.3 million and \$0.4 million for 2009 and 2008, respectively. Also including interest rate swap adjustments of \$17.8 million and \$8.5 million in 2009 and 2008, respectively	\$ 317,433	\$ 308,057
Credit Agreement:		
U.S. Dollar-denominated borrowings, 0.75% in 2009, due 2011	133,400	-
Total credit agreement borrowing	133,400	-
Capital leases with terms expiring through 2015 and 1.8% to 4.4% in 2009 and 4.1% to 6.0% in 2008	6,364	5,259
Other	542	549
Total debt and capital leases	457,739	313,865
Less current maturities:		
Long-term debt	(18,558)	(148)
Capital leases	(2,589)	(665)
Total current maturities	(21,147)	(813)
Long-term debt and capital leases, less current maturities	\$ 436,592	\$ 313,052

Senior Unsecured Notes On June 19, 2002, we issued \$300 million of 7.2 percent Senior Unsecured Notes due 2012 (Senior Unsecured Notes). These notes were issued at 99.629 percent of the face amount and yielded \$294.3 million of net proceeds after related financing fees. The proceeds of this debt issuance were utilized to repay senior bank indebtedness. Interest is payable semi-annually on June 15 and December 15 of each year. The Senior Unsecured Notes contain covenants that restrict our ability to create liens, enter into sale-leaseback transactions or certain consolidations or mergers, or sell all or substantially all of our assets. Prior to February 2009, we had interest rate swap agreements with a notional amount of \$200 million and a maturity date of June 2012. During the period when these agreements were in effect, we recorded the gain or loss on these agreements as an asset or a liability, as applicable, with the offset to the carrying value of the debt. In February 2009, we terminated these agreements. Upon termination, we received a cash payment of \$13.2 million. The gain is being amortized as a component of interest expense over the remaining term of the related debt using the effective interest rate method. As of June 30, 2008, the fair value of our interest rate swap agreements was an asset of \$0.7 million.

2006 Credit Agreement In March 2006, we entered into a five-year, multi-currency, revolving credit facility with a group of financial institutions (2006 Credit Agreement). The 2006 Credit Agreement permits revolving credit loans of up to \$500.0 million for working capital, capital expenditures and general corporate purposes. The 2006 Credit Agreement allows for borrowings in U.S. dollars, euros, Canadian dollars, pound sterling and Japanese yen. Interest payable under the 2006 Credit Agreement is based upon the type of borrowing under the facility and may be (1) LIBOR plus an applicable margin, (2) the greater of the prime rate or the Federal Funds effective rate plus 0.5 percent or (3) fixed as negotiated by us.

The 2006 Credit Agreement requires us to comply with various restrictive and affirmative covenants, including two financial covenants: a maximum leverage ratio and a minimum consolidated interest coverage ratio (as those terms are defined in the agreement). We were in compliance with these financial covenants as of June 30, 2009. Borrowings under the 2006 Credit Agreement as of June 30, 2009 were \$133.4 million that were used in part to finance the repurchase of \$127.7 million in capital stock during the year ended June 30, 2009.

Borrowings under the 2006 Credit Agreement are guaranteed by our significant domestic subsidiaries.

On July 6, 2009, we entered into an amendment to our 2006 Credit Agreement. The amendment provides for the exclusion of certain cash restructuring charges from the earnings component used in the calculation of the leverage and interest ratios. In addition, the amendment provides for an increase in the permitted leverage ratio for certain quarterly measurement dates. The amendment also provides restrictions on share repurchases and securitizations, as well as future acquisitions and capital leases should leverage ratios exceed the permitted ratio that prevailed prior to the amendment. Furthermore, the amendment would require security interest in our domestic accounts receivable and inventories should our leverage ratio exceed a certain threshold. The amendment includes an increase in interest rates on borrowings of approximately 200 basis points.

Future principal maturities of long-term debt are \$0.2 million, \$152.0 million, \$317.6 million and \$0.1 million, respectively, in 2010 through 2013.

Future minimum lease payments under capital leases for the next five years and thereafter in total are as follows:

(in thousands)	
2010	\$ 2,758
2011	1,350
2012	1,353
2013	886
2014	305
After 2014	102
Total future minimum lease payments	6,754
Less amount representing interest	(390)
Amount recognized as capital lease obligations	\$ 6,364

Our collateralized debt at June 30, 2009 and 2008 was comprised of industrial revenue bond obligations of \$0.3 million and \$0.4 million, respectively, and the capitalized lease obligations of \$6.4 million and \$5.3 million, respectively. The underlying assets collateralize these obligations.

NOTE 12 - NOTES PAYABLE AND LINES OF CREDIT

Notes payable to banks of \$28.2 million and \$32.8 million at June 30, 2009 and 2008, respectively, represent short-term borrowings under credit lines with commercial banks. These credit lines, translated into U.S. dollars at June 30, 2009 exchange rates, totaled \$187.7 million at June 30, 2009, of which \$159.5 million was unused. The weighted average interest rate for notes payable and lines of credit was 3.3 percent and 4.8 percent at June 30, 2009 and 2008, respectively.

NOTE 13 - INCOME TAXES

Income from continuing operations before income taxes and minority interest expense and the provision for income taxes consisted of the following for the years ended June 30:

(in thousands)	2009	2008	2007
(Loss) income from continuing operations before income taxes and minority interest expense:			
United States	\$ (135,133)	\$ 9,137	\$ 83,287
International	22,637	220,263	161,866
Total (loss) income from continuing operations before income taxes and minority interest expense	\$ (112,496)	\$ 229,400	\$ 245,153
Current income taxes:			
Federal	\$ (25,071)	\$ 315	\$ 36,737
State	2,019	499	615
International	21,169	30,067	39,938
Total current income taxes	(1,883)	30,881	77,290
Deferred income taxes	(9,322)	31,873	(9,039)
Provision for income taxes	\$ (11,205)	\$ 62,754	\$ 68,251
Effective tax rate	10.0%	27.4%	27.8%

The reconciliation of income taxes computed using the statutory U.S. income tax rate and the provision for income taxes was as follows for the years ended June 30:

(in thousands)	2009	2008	2007
Income taxes at U.S. statutory rate	\$ (39,374)	\$ 80,290	\$ 85,804
State income taxes, net of federal tax benefits	(131)	2,339	333
Combined tax effects of international income	4,868	(32,891)	(17,894)
Change in valuation allowance and other uncertain tax positions	(4,638)	1,057	5,226
Impact of goodwill impairment charges	29,296	12,250	-
Research and development credit	(1,501)	(984)	(3,908)
Other	275	693	(1,310)
Provision for income taxes	\$ (11,205)	\$ 62,754	\$ 68,251

During 2009, we recorded goodwill impairment charges related to our surface finishing machines and services business and our engineered products business for the majority of which there was no tax benefit. The federal effect of these permanent differences is included in the income tax reconciliation table under the caption "Impact of goodwill impairment charges."

During 2009, the Internal Revenue Service completed its examination of our 2005 and 2006 tax years, which resulted in a net tax benefit of \$1.8 million, including the impact of state taxes and interest. The federal effect of this benefit is included in the income tax reconciliation table under the caption "Change in valuation allowance and other uncertain tax positions."

During 2009, we recorded a valuation allowance adjustment of \$2.8 million, which reduced income tax expense. This valuation allowance adjustment reflects a change in circumstances that caused a change in judgment about the realizability of certain deferred tax assets in Europe. The effect of this tax benefit is included in the income tax reconciliation table under the caption "Change in valuation allowance and other uncertain tax positions."

During 2008, we recorded a goodwill impairment charge related to our surface finishing machines and services business for which there was no tax benefit. The federal effect of this permanent difference is included in the income tax reconciliation table under the caption "Impact of goodwill impairment charges."

During 2008, the German government enacted a tax reform bill that included a reduction of its corporate income tax rate. As a result, we adjusted the balance of our net deferred tax assets in Germany for the effect of this change in tax rate, which increased deferred tax expense by \$6.6 million. The effect of this tax expense is included in the income tax reconciliation table under the caption "Combined tax effects of international income."

During 2008, we concluded that a change in our determination with respect to cumulative undistributed earnings of international subsidiaries and affiliates was warranted whereby we believe unremitted previously taxed income of our international subsidiaries is not permanently reinvested. As a result of this change, we accrued an income tax liability of \$3.0 million. Of this amount, \$2.1 million decreased accumulated other comprehensive income and \$0.9 million increased tax expense. The effect of this tax expense is included in the income tax reconciliation table under the caption "Combined tax effects of international income."

During 2007, we recorded a tax charge of \$8.1 million related to tax contingencies in Europe. The effect of this tax expense is included in the income tax reconciliation table under the caption "Change in valuation allowance and other uncertain tax positions."

During 2007, we recorded a valuation allowance adjustment of \$2.7 million, which reduced income tax expense. This valuation allowance adjustment reflects a change in circumstances that caused a change in judgment about the realizability of deferred tax assets related to net operating loss carryforwards for state income tax purposes. The effect of this tax benefit is included in the income tax reconciliation table under the caption "Change in valuation allowance and other uncertain tax positions."

The components of net deferred tax assets and liabilities were as follows at June 30:

(in thousands)	2009	2008
Deferred tax assets:		
Net operating loss carryforwards	\$ 68,777	\$ 67,822
Inventory valuation and reserves	23,567	23,673
Pension benefits	4,637	4,016
Other postretirement benefits	10,534	12,551
Accrued employee benefits	22,399	27,978
Other accrued liabilities	4,629	8,968
Hedging activities	16,036	19,902
Tax credits and other carryforwards	7,820	1,821
Other	1,965	-
Total	160,364	166,731
Valuation allowance	(48,206)	(46,650)
Total deferred tax assets	\$ 112,158	\$ 120,081
Deferred tax liabilities:		
Tax depreciation in excess of book	\$ 79,306	\$ 78,141
Intangible assets	32,878	43,010
Other	-	1,761
Total deferred tax liabilities	\$ 112,184	\$ 122,912
Total net deferred tax (liabilities) assets	\$ (26)	\$ (2,831)

Included in deferred tax assets at June 30, 2009 were unrealized tax benefits totaling \$68.8 million related to net operating loss carryforwards for foreign and state income tax purposes. Of that amount, \$9.4 million expire through June 2014, \$7.1 million expire through 2019, \$3.4 million expire through 2024, \$7.6 million expire through 2029, and the remaining \$41.3 million do not expire. The realization of these tax benefits is primarily dependent on future taxable income in these jurisdictions.

A valuation allowance of \$48.2 million has been placed against deferred tax assets in Europe, China, Hong Kong, Mexico, Brazil and the U.S., which would be allocated to income tax expense upon realization of these tax benefits. In 2009, the valuation allowance related to these deferred tax assets increased \$1.6 million.

As the respective operations generate sufficient income, the valuation allowances will be partially or fully reversed at such time we believe it will be more likely than not that the deferred tax assets will be realized.

As of June 30, 2009, the unremitted earnings of our non-U.S. subsidiaries and affiliates that have not been previously taxed in the U.S. are permanently reinvested, and accordingly, no deferred tax liability has been recorded in connection therewith. It is not practical to estimate the income tax effect that might be incurred if earnings not previously taxed in the U.S. were remitted to the United States.

Effective July 1, 2007, we adopted FASB Interpretation No. 48, "Accounting for Uncertainty in Income Taxes – an Interpretation of FASB Statement No. 109" (FIN 48).

A reconciliation of the beginning and ending amount of unrecognized tax benefits (excluding interest) is as follows as of June 30:

(in thousands)	2009		2008	
Balance at beginning of year	\$	24,207	\$	20,306
Increases for tax positions of prior years		943		2,415
Decreases for tax positions of prior years		(216)		(619)
Increases for tax positions related to the current year		116		338
Decreases related to settlement with taxing authority		(7,724)		-
Foreign currency translation		(1,509)		1,767
Balance at end of year	\$	15,817	\$	24,207

The total amount of unrecognized tax benefits that, if recognized, would affect the effective tax rate in 2009 and 2008 is \$15.2 million and \$21.3 million, respectively.

Our policy is to recognize interest and penalties related to income taxes as a component of the provision for income taxes in the consolidated statement of income. During 2009, we recognized an interest reduction of \$0.8 million, and in 2008, we accrued \$1.4 million of interest. As of June 30, 2009 and 2008, the amount of interest accrued was \$1.6 million and \$3.7 million, respectively.

With few exceptions, we are no longer subject to income tax examinations by tax authorities for years prior to 2002. The Internal Revenue Service has audited all U.S. tax years prior to 2007 and has begun its examination of 2007 and 2008. Various state and foreign jurisdiction tax authorities are in the process of examining our income tax returns for various tax years ranging from 2002 to 2007. We continue to execute and expand our pan-European business model. As a result of this and other matters, we continuously review our uncertain tax positions and evaluate any potential issues that may lead to an increase or decrease in the total amount of unrecognized tax benefits recorded. We believe that it is reasonably possible that the amount of unrecognized tax benefits could decrease by approximately \$10.0 million to \$11.0 million within the next twelve months as a result of the progression of various federal, state and foreign audits in process.

NOTE 14 - PENSION AND OTHER POSTRETIREMENT AND POSTEMPLOYMENT BENEFITS

We sponsor several pension plans. Effective January 1, 2004, no new non-union employees are eligible to participate in our U.S. Retirement Income Plan (RIP Plan). Benefits under the RIP Plan continue to accrue only for certain employees. Pension benefits under defined benefit pension plans are based on years of service and, for certain plans, on average compensation immediately preceding retirement. We fund pension costs in accordance with the funding requirements of the Employee Retirement Income Security Act of 1974 (ERISA), as amended, for U.S. plans and in accordance with local regulations or customs for non-U.S. plans.

Additionally, we maintain a Supplemental Executive Retirement Plan (SERP) and a 2006 Executive Retirement Plan (ERP) for various executives. The liability associated with these plans is also included in the pension disclosures below. On July 26, 2006, the SERP was amended and the ERP was established. Participants in the SERP who reached the age of 56 by December 31, 2006 are "grandfathered" under the SERP and will continue to accrue benefits in accordance with the provisions of the SERP. These SERP "grandfathered" participants are not eligible to participate in the ERP. Participants in the SERP who did not reach the age of 56 by December 31, 2006 were eligible to either retain their accrued benefits under the SERP, frozen as of July 31, 2006, or participate in the ERP with respect to future as well as prior service. The SERP is closed to new participants. Eligible officers hired after July 31, 2006 may participate in the ERP, regardless of age. Neither the amendment to the SERP nor the establishment of the ERP had a material impact on our consolidated financial statements.

We presently provide varying levels of postretirement health care and life insurance benefits (OPEB) to most U.S. employees. Postretirement health care benefits are available to employees and their spouses retiring on or after age 55 with 10 or more years of service. Beginning with retirements on or after January 1, 1998, our portion of the costs of postretirement health care benefits is

capped at 1996 levels. Beginning with retirements on or after January 1, 2009, we have no obligation to provide a company subsidy for retiree medical costs.

In 2008, the Company approved the conversion of a U.K.-based defined benefit pension plan to a defined contribution plan. This conversion resulted in a curtailment loss for pension cost of \$1.7 million for 2008 which was recognized in operating expense. In 2009, we recognized a curtailment gain for OPEB of \$3.2 million resulting from a plant closure of which \$1.9 million was recorded in cost of goods sold and \$1.3 million was recognized in operating expense. In 2008, we recognized a curtailment loss for pension cost of \$0.4 million related to this same plant closure of which \$0.2 million was recognized in cost of goods sold and \$0.2 million was recognized in operating expense.

In 2009, special one time termination benefits of \$2.7 million were recognized in the U.S. based defined benefit pension plan due to an amendment of the plan for supplemental retirement benefits.

We use a June 30 measurement date for all of our plans.

Defined Benefit Pension Plans

The funded status of our pension plans and amounts recognized in the consolidated balance sheets as of June 30 were as follows:

(in thousands)	2009	2008
Change in benefit obligation:		
Benefit obligation, beginning of year	\$ 666,559	\$ 670,696
Service cost	7,824	10,024
Interest cost	41,652	39,900
Participant contributions	194	661
Actuarial losses (gains)	30,765	(32,697)
Benefits and expenses paid	(36,638)	(34,444)
Foreign currency translation adjustment	(25,307)	14,604
Plan amendments	2,651	1,447
Plan curtailments	-	(3,632)
Benefit obligation, end of year	\$ 687,700	\$ 666,559
Change in plan assets:		
Fair value of plan assets, beginning of year	\$ 595,744	\$ 642,718
Actual return on plan assets	59,652	(19,552)
Company contributions	6,741	6,058
Participant contributions	193	661
Benefits and expenses paid	(36,638)	(34,444)
Foreign currency translation adjustments	(18,817)	303
Fair value of plan assets, end of year	\$ 606,875	\$ 595,744
Funded status of plan	\$ (80,825)	\$ (70,815)
Amounts recognized in the balance sheet consist of:		
Long-term prepaid benefit	\$ 40,196	\$ 41,516
Short-term accrued benefit obligation	(6,782)	(6,751)
Accrued pension benefits	(114,239)	(105,580)
Net amount recognized	\$ (80,825)	\$ (70,815)

We adopted SFAS No. 158, "Employers' Accounting for Defined Benefit Pension and Other Postretirement Plans – an Amendment of FASB Statements No. 87, 88, 106, and 123(R)" (SFAS 158) on June 30, 2007, which required us to record the funded status of our defined benefit pension plans in the balance sheet.

The pre-tax amounts related to our defined benefit pension plans recognized in accumulated other comprehensive income were as follows at June 30:

(in thousands)	2009		2008	
Unrecognized net actuarial losses	\$	99,784	\$	86,102
Unrecognized net prior service credits		(2,780)		(2,963)
Unrecognized transition obligations		1,365		1,750
Total	\$	98,369	\$	84,889

Prepaid pension benefits are included in other long-term assets. The assets of our U.S. and international defined benefit pension plans consist principally of capital stocks, corporate bonds and government securities.

To the best of our knowledge and belief, the asset portfolios of our defined benefit pension plans do not contain our capital stock. We do not issue insurance contracts to cover future annual benefits of defined benefit pension plan participants. Transactions between us and our defined benefit pension plans include the reimbursement of plan expenditures incurred by us on behalf of the plans. To the best of our knowledge and belief, the reimbursement of cost is permissible under current ERISA rules or local government law.

The accumulated benefit obligation for all defined benefit pension plans was \$670.1 million and \$646.4 million as of June 30, 2009 and 2008, respectively.

Included in the above information are pension plans with accumulated benefit obligations exceeding the fair value of plan assets as of June 30 as follows:

(in thousands)	2009		2008	
Projected benefit obligation	\$	114,384	\$	112,331
Accumulated benefit obligation		113,348		111,281
Fair value of plan assets		-		-

The components of net periodic pension cost include the following as of June 30:

(in thousands)	2009		2008		2007	
Service cost	\$	7,824	\$	10,024	\$	9,934
Interest cost		41,652		39,900		37,920
Expected return on plan assets		(46,939)		(49,241)		(45,097)
Amortization of transition obligation		63		166		153
Amortization of prior service credit		(213)		(41)		(9)
Special termination benefit		2,651		-		-
Curtailement loss		-		2,078		-
Recognition of actuarial losses		1,900		2,255		5,779
Net periodic pension cost	\$	6,938	\$	5,141	\$	8,680

Net periodic pension cost increased \$1.8 million to \$6.9 million in 2009 from \$5.1 million in 2008. This increase was primarily the result of pension asset losses, demographic losses and recognition of special termination charges.

Net periodic pension cost decreased \$3.6 million to \$5.1 million in 2008 from \$8.7 million in 2007. This decrease was primarily the result of an increase in plan assets and increases in discount rates used to determine our net periodic pension cost for our international plans partially offset by the impact of the curtailment charges previously discussed. See disclosure of discount rate assumptions within this note.

As of June 30, 2009, the projected benefit payments including future service accruals for these plans for 2010 through 2014 is \$37.4 million, \$37.4 million, \$39.2 million, \$41.6 million and \$43.3 million, respectively and \$249.7 million in 2015 through 2019.

The amounts of accumulated other comprehensive loss expected to be recognized in net periodic pension cost during 2010 related to net actuarial losses and transition obligations are \$4.5 million and \$0.1 million, respectively. The amount of accumulated other comprehensive income expected to be recognized in net periodic pension cost during 2010 related to prior service credit is \$0.3 million.

Our defined benefit pension plans' asset allocations as of June 30, 2009 and 2008 and target allocations for 2010, by asset class, were as follows:

	2009	2008	Target %
Equity	36%	44%	33-34%
Fixed Income	60%	54%	66-67%
Other	4%	2%	0%

The primary objective of the pension plans' investment policies is to ensure that sufficient assets are available to provide the benefit obligations at the time the obligations come due. Investment management practices must comply with ERISA and all applicable regulations and rulings thereof.

The overall investment strategy for the defined benefit pension plans' assets combines considerations of preservation of principal and moderate risk-taking. The assumption of an acceptable level of risk is warranted in order to achieve satisfactory results consistent with the long-term objectives of the portfolio. Fixed income securities comprise a significant portion of the portfolio due to their plan-liability-matching characteristics and to address the plans' cash flow requirements. Additionally, diversification of investments within each asset class is utilized to further reduce the impact of losses in single investments.

During 2008, the Company adjusted its overall investment strategy for the assets of its U.S. defined benefit pension plans. In order to reduce the volatility of the funded status of these plans and to meet the obligations at an acceptable cost over the long term, the Company implemented a liability driven investment (LDI) strategy. This LDI strategy entails modifying the asset allocation and duration of the assets of the plans to more closely match the liability profile of these plans. The asset reallocation involves increasing the fixed income allocation, reducing the equity component and adding alternative investments. Longer duration interest rate swaps have been added in order to increase the overall duration of the asset portfolio to more closely match the liabilities.

We expect to contribute \$7.3 million to our pension plans in 2010.

Other Postretirement Benefit Plans

The funded status of our other postretirement benefit plans and the related amounts recognized in the consolidated balance sheets were as follows:

(in thousands)	2009	2008
Change in benefit obligation:		
Benefit obligation, beginning of year	\$ 26,136	\$ 29,047
Service cost	294	533
Interest cost	1,631	1,734
Actuarial gain	(1,893)	(1,262)
Plan curtailments	(3,199)	-
Benefits paid	(2,371)	(3,916)
Benefit obligation, end of year	\$ 20,598	\$ 26,136
Funded status of plan	\$ (20,598)	\$ (26,136)
Amounts recognized in the balance sheet consist of:		
Short-term accrued benefit obligation	(2,050)	(2,537)
Accrued postretirement benefits	(18,548)	(23,599)
Net amount recognized	\$ (20,598)	\$ (26,136)

The pre-tax amounts related to our OPEB plans which were recognized in accumulated other comprehensive income were as follows at June 30:

(in thousands)	2009	2008
Unrecognized net actuarial losses	\$ (5,156)	\$ (3,370)
Unrecognized net prior service cost	8	77
Total	\$ (5,148)	\$ (3,293)

The components of net periodic other postretirement costs (benefit) include the following for the years ended June 30:

(in thousands)	2009	2008	2007
Service cost	\$ 294	\$ 533	\$ 533
Interest cost	1,631	1,734	1,679
Amortization of prior service cost	39	47	47
Recognition of actuarial gains	(107)	(525)	(1,465)
Curtailment gain	(3,169)	-	-
Net periodic other postretirement benefit cost	\$ (1,312)	\$ 1,789	\$ 794

As of June 30, 2009, the projected benefit payments, including future service accruals for our other postretirement benefit plans for 2010 through 2014, is \$2.5 million, \$2.5 million, \$2.4 million, \$2.4 million and \$2.3 million, respectively and \$9.4 million in 2015 through 2019.

The amounts of accumulated other comprehensive income expected to be recognized in net periodic other postretirement benefit cost during 2010 related to net actuarial gains are immaterial for prior service cost.

We expect to contribute \$2.3 million to our postretirement benefit plans in 2010.

Assumptions

The significant actuarial assumptions used to determine the present value of net benefit obligations for our defined benefit pension plans and other postretirement benefit plans were as follows:

	2009	2008	2007
Discount Rate:			
U.S. plans	6.5%	6.8%	6.3%
International plans	5.8-7.0%	6.3 -6.8%	5.3 -5.8%
Rates of future salary increases:			
U.S. plans	3.0 -5.0%	3.0 -5.0%	3.0 -5.0%
International plans	3.5%	3.5 -4.0%	3.5 -4.5%

The significant assumptions used to determine the net periodic costs (benefits) for our pension and other postretirement benefit plans were as follows:

	2009	2008	2007
Discount Rate:			
U.S. plans	6.8%	6.3%	6.3%
International plans	6.3 -6.8%	5.3 -5.8%	4.8 -5.8%
Rates of future salary increases:			
U.S. plans	3.0 -5.0%	3.0 -5.0%	3.0 -5.0%
International plans	3.5-4.0%	3.5 -4.5%	3.5 -4.3%
Rate of return on plans assets:			
U.S. plans	8.0%	8.3%	8.3%
International plans	7.1%	7.5%	7.1%

The rates of return on plan assets are based on historical performance as well as future expected returns by asset class considering macroeconomic conditions, current portfolio mix, long-term investment strategy and other available relevant information.

The annual assumed rate of increase in the per capita cost of covered benefits (the health care cost trend rate) for our postretirement benefit plans was as follows:

	2009	2008	2007
Health care costs trend rate assumed for next year	8.8%	8.7%	9.5%
Rate to which the cost trend rate gradually declines	4.5%	5.0%	5.0%
Year that the rate reaches the rate at which it is assumed to remain	2029	2014	2014

Assumed health care cost trend rates have a significant effect on the cost components and obligation for the health care plans. A change of one percentage point in the assumed health care cost trend rates would have the following effects on the total service and interest cost components of our other postretirement cost and other postretirement benefit obligation at June 30, 2009:

(in thousands)	1% Increase	1% Decrease
Effect on total service and interest cost components	\$ 129	\$ (111)
Effect on other postretirement obligation	917	(818)

Defined Contribution Plans

We also sponsor several defined contribution retirement plans. Costs for defined contribution plans were \$20.3 million, \$27.5 million and \$26.0 million in 2009, 2008 and 2007, respectively. Effective March 2009, the company temporarily suspended the making of matching contributions to its U.S. defined contribution plans.

Effective March 2009, as well as for a portion of 2007, company contributions to U.S. defined contribution plans were made primarily in our capital stock. During other periods within 2007 through 2009, employer contributions were invested in the same investment fund elections that the employee elected for their contributions. The issuance of capital stock for the company contributions in 2009 was 82,736 shares with a market value of \$1.5 million. Issuance of capital stock for this purpose in 2007 was 191,890 shares with a market value of \$5.6 million.

NOTE 15 – COMPREHENSIVE INCOME AND ACCUMULATED OTHER COMPREHENSIVE INCOME (LOSS)

(in thousands)	2009	2008	2007
Net (loss) income	\$ (119,742)	\$ 167,775	\$ 174,243
Unrealized (loss) gain on derivatives designated and qualified as cash flow hedges, net of income tax (benefit) expense of (\$1.9) million, \$1.5 million and \$0.6 million, respectively	(3,006)	2,412	1,035
Reclassification of unrealized loss (gain) on expired derivatives designated and qualified as cash flow hedges, net of income tax of (\$3.3) million, \$1.5 million and \$1.0 million, respectively	5,290	(2,452)	(1,682)
Unrecognized net pension and other postretirement benefit losses, net of income tax benefit of \$0.1 million and \$11.0 million, respectively	(14,283)	(21,393)	-
Reclassification of net pension and other postretirement benefit losses, net of income tax benefit of \$0.5 million and \$0.7 million, respectively	1,496	3,249	-
Minimum pension liability adjustment, net of income tax expense of \$5.5 million	-	-	8,348
Foreign currency translation adjustments, net of income tax (benefit) expense of (\$73.5) million, \$60.9 million and \$28.9 million, respectively	(119,887)	98,619	46,739
Comprehensive (loss) income	\$ (250,132)	\$ 248,210	\$ 228,683

The components of accumulated other comprehensive income consist of the following at June 30 (in thousands):

2009	Pre-tax	Tax	After-tax
Unrealized gain on derivatives designated and qualified as cash flow hedges \$	607	\$(48)	\$ 559
Unrecognized net actuarial losses	(93,977)	24,687	(69,290)
Unrecognized net prior service credit	3,029	(1,304)	1,725
Unrecognized transition obligation	(1,413)	(88)	(1,501)
Foreign currency translation adjustments	76,824	3,402	80,226
Total accumulated other comprehensive income	\$ (14,930)	\$ 26,649	\$ 11,719

2008	Pre-tax	Tax	After-tax
Unrealized loss on derivatives designated and qualified as cash flow hedges \$	(2,782)	\$ 1,057	\$(1,725)
Unrecognized net actuarial losses	(80,485)	24,341	(56,144)
Unrecognized net prior service credit	2,891	(1,099)	1,792
Unrecognized transition obligation	(1,751)	(176)	(1,927)
Foreign currency translation adjustments	270,182	(70,069)	200,113
Total accumulated other comprehensive income	\$ 188,055	\$ (45,946)	\$ 142,109

NOTE 16 - RESTRUCTURING AND ASSET IMPAIRMENT CHARGES

Restructuring During 2009, we continued to implement restructuring plans to reduce costs and improve operating efficiencies. These actions relate to the rationalization of certain manufacturing and service facilities as well as other employment and cost reduction programs. Restructuring and related charges recorded in 2009 amounted to \$73.3 million, including \$64.7 million of restructuring charges of which \$2.1 million were related to inventory disposals and recorded in cost of goods sold. Restructuring related charges of \$8.8 million were recorded in cost of goods sold and a net restructuring related benefit of \$0.2 million was recorded in operating expense during 2009.

Total restructuring and related charges since the inception of the restructuring plans through June 30, 2009 were \$81.5 million. Including these charges, we expect to recognize approximately \$115 million of pre-tax charges related to our restructuring plans. The majority of the remaining charges are expected to be incurred by December 31, 2009, most of which are expected to be cash expenditures. We realized pre-tax benefits of approximately \$50 million from these actions in fiscal 2009 and expect to realize approximately \$75 million of additional pre-tax benefits in fiscal 2010. This would bring the annual ongoing pre-tax benefits from these actions to approximately \$125 million.

The restructuring accrual is recorded in other current liabilities in our consolidated balance sheet and the amount attributable to each segment is as follows:

(in thousands)	2008	Expense	Asset Write-down	Cash Expenditures	Translation	2009
MSSG						
Severance	\$ 3,070	\$ 42,938	\$ -	\$ (26,613)	\$ 593	\$ 19,988
Facilities	-	1,738	(1,159)	(63)	2	518
Other	131	1,075	-	(1,035)	30	201
Total MSSG	3,201	45,751	(1,159)	(27,711)	625	20,707
AMSG						
Severance	1,749	10,896	-	(8,252)	72	4,465
Facilities	-	3,310	(3,015)	(135)	(2)	158
Other	-	225	-	(165)	(12)	48
Total AMSG	1,749	14,431	(3,015)	(8,552)	58	4,671
Corporate						
Severance	-	5,042	-	(3,501)	43	1,584
Other	-	139	-	(139)	-	-
Total Corporate	-	5,181	-	(3,640)	43	1,584
Total	\$ 4,950	\$ 65,363	\$ (4,174)	\$ (39,903)	\$ 726	\$ 26,962

Asset impairment

See discussion of our 2009 and 2008 AMGS goodwill and indefinite-lived trademark impairment charges in Note 2 under the caption “Goodwill and Intangible Assets.”

See discussion of our 2007 MSSG Widia trademark impairment charge in Note 2 under the caption “Goodwill and Intangible Assets.”

NOTE 17 — FINANCIAL INSTRUMENTS

The methods used to estimate the fair value of our financial instruments are as follows:

Cash and Equivalents, Current Maturities of Long-Term Debt and Notes Payable to Banks The carrying amounts approximate their fair value because of the short maturity of the instruments.

Long-Term Debt Fixed rate debt had a fair market value of \$314.1 million and \$315.9 million at June 30, 2009 and 2008, respectively. The fair value is determined based on the quoted market price of this debt as of June 30.

Foreign Exchange Contracts The notional amount of outstanding foreign exchange contracts, translated at current exchange rates, was \$1.7 million and \$126.5 million at June 30, 2009 and 2008, respectively. We would have received \$0.2 million at June 30, 2009, and paid \$0.3 million at June 30, 2008, respectively, to settle these contracts, representing the fair value of these agreements. The carrying value equaled the fair value for these contracts at June 30, 2009 and 2008. Fair value was estimated based on quoted market prices of comparable instruments.

Interest Rate Swap Agreements We terminated our interest rate swap agreements in February 2009 and received cash of \$13.2 million. As of June 30, 2008, the fair value of our interest rate swap agreements was an asset of \$0.7 million. The carrying value equaled the fair value for the interest rate swap agreements at June 30, 2008. Fair value was estimated based on the mark-to-market value of the contracts, which closely approximates the amount that we would receive or pay to terminate the agreements at the balance sheet date.

Concentrations of Credit Risk Financial instruments that potentially subject us to concentrations of credit risk consist primarily of temporary cash investments and trade receivables. By policy, we make temporary cash investments with high credit quality financial institutions and limit the amount of exposure to any one financial institution. With respect to trade receivables, concentrations of credit risk are significantly reduced because we serve numerous customers in many industries and geographic areas.

We are exposed to counterparty credit risk for nonperformance of derivatives and, in the unlikely event of nonperformance, to market risk for changes in interest and currency rates, as well as settlement risk. We manage exposure to counterparty credit risk through credit standards, diversification of counterparties and procedures to monitor concentrations of credit risk. We do not anticipate nonperformance by any of the counterparties. As of June 30, 2009 and 2008, we had no significant concentrations of credit risk.

NOTE 18 — STOCK-BASED COMPENSATION

The assumptions used in our Black-Scholes valuation related to grants made during 2009, 2008 and 2007 were as follows:

	2009	2008	2007
Risk-free interest rate	3.0%	4.4%	4.9%
Expected life (years) ⁽¹⁾	4.5	4.5	4.5
Expected volatility ⁽²⁾	27.7%	23.6%	22.4%
Expected dividend yield	1.3%	1.4%	1.4%

1) Expected life is derived from historical experience.

2) Expected volatility is based on the implied historical volatility of our capital stock.

Changes in our capital stock options for 2009 were as follows:

2009	Options	Weighted Average Exercise Price	Weighted Average Remaining Life (years)	Aggregate Intrinsic value (in thousands)
Options outstanding, June 30, 2008	3,148,214	\$ 24.87		
Granted	798,510	29.16		
Exercised	(194,964)	14.60		
Lapsed and forfeited	(362,405)	29.75		
Options outstanding, June 30, 2009	3,389,355	\$ 25.95	6.1	\$ 2,063
Options vested and expected to vest, June 30, 2009	3,324,066	\$ 25.85	6.0	\$ 2,063
Options exercisable, June 30, 2009	1,956,777	\$ 22.45	4.7	\$ 2,063

Weighted average fair value of options granted during 2009, 2008 and 2007 was \$7.15, \$9.37, and \$6.54, respectively. Fair value of options vested during 2009, 2008 and 2007 was \$3.5 million, \$3.6 million, and \$5.2 million, respectively.

Tax benefits relating to excess stock-based compensation deductions are presented in the statement of cash flow as financing cash inflows. Tax benefits resulting from stock-based compensation deductions in excess of amounts reported for financial reporting purposes were \$0.9 million, \$3.2 million and \$6.9 million in 2009, 2008 and 2007, respectively.

The amount of cash received from the exercise of capital stock options during 2009, 2008 and 2007 was \$2.2 million, \$9.7 million, and \$33.8 million, respectively. The related tax benefit was \$1.1 million, \$2.4 million, and \$6.7 million for 2009, 2008 and 2007, respectively. The total intrinsic value of capital stock options exercised during 2009, 2008 and 2007 was \$3.0 million, \$8.3 million, and \$21.7 million, respectively. During 2009, 2008 and 2007, compensation expense related to capital stock options was \$4.0 million, \$3.5 million and \$4.6 million, respectively. As of June 30, 2009, the total unrecognized compensation cost related to capital stock options outstanding was \$4.8 million and is expected to be recognized over a weighted average period of 2.3 years.

Changes in our restricted stock for 2009 were as follows:

2009	Shares	Weighted Average Fair Value
Unvested restricted stock, June 30, 2008	486,591	\$ 31.55
Granted	175,302	29.25
Vested	(134,176)	29.35
Lapsed and forfeited	(107,956)	28.87
Unvested restricted stock, June 30, 2009	419,761	\$ 31.99

During 2009, 2008 and 2007, compensation expense related to restricted stock awards was \$4.5 million, \$4.6 million and \$6.1 million, respectively. As of June 30, 2009, the total unrecognized compensation cost related to unvested restricted stock was \$6.1 million and is expected to be recognized over a weighted average period of 2.2 years.

On November 26, 2007, the Company adopted a long-term, one-time equity program, the Kennametal Inc. 2008 Strategic Transformational Equity Program, under the 2002 Plan (the Program). The Program will compensate participating executives for achievement of certain performance conditions during the period which began on October 1, 2007 and ends on September 30, 2011. Each participant is awarded a maximum number of restricted stock units, each representing a contingent right to receive one share of capital stock of the Company to the extent the unit is earned during the performance period and becomes payable under the Program. The performance conditions are based on the Company's total shareholder return (TSR), which governs 35 percent of the awarded restricted stock units, and cumulative adjusted earnings per share (EPS), which governs 65 percent of the awarded restricted stock units. As of June 30, 2009, participating executives have been granted awards equal to that number of restricted stock units having a value of \$34.3 million. A further amount of \$3.0 million is available under the Program for additional awards that may be made to other executives. There are no voting rights or dividends associated with these restricted stock units.

Under the Program, participants may earn up to a cumulative 35 percent of the maximum restricted stock units awarded if certain threshold levels of the performance conditions are achieved through two interim dates of September 30, 2009 and 2010. Generally, the

payment of any restricted stock units under the Program is conditioned upon the participants being employed by the Company on the date of payment and the satisfaction of all other provisions of the Program.

The assumptions used in our valuation of the EPS performance-based portion of the restricted stock units granted under the Program during 2009 and 2008 were as follows:

	2009	2008
Expected quarterly dividend per share	\$ 0.12	\$ 0.12
Risk-free interest rate	2.3%	3.3%

Changes in the EPS performance-based restricted stock units for 2009 were as follows:

	Stock Units	Weighted Average Fair Value
Unvested EPS performance-based restricted stock units, June 30, 2008	531,435	\$ 37.45
Granted	95,492	23.21
Forfeited	(58,127)	37.45
Unvested EPS performance-based restricted stock units, June 30, 2009	568,800	\$ 35.06

As of June 30, 2009, we assumed that none of the EPS performance-based restricted stock units will vest.

The assumptions used in our lattice model valuation for the TSR performance-based portion of the restricted stock units granted during 2009 and 2008 were as follows:

	2009	2008
Expected volatility	34.1%	24.1%
Expected dividend yield	2.0%	1.2%
Risk-free interest rate	2.3%	3.3%

Changes in the TSR performance-based restricted stock units for 2009 were as follows:

	Stock Units	Weighted Average Fair Value
Unvested TSR performance-based restricted stock units, June 30, 2008	286,149	\$ 9.20
Granted	51,418	2.08
Forfeited	(31,297)	9.20
Unvested TSR performance-based restricted stock units, June 30, 2009	306,270	\$ 8.01

Based on a change in the probability of achieving the performance criteria related to the vesting of the EPS performance-based portion of the restricted stock units, we reversed previously recognized compensation expense related to these units. The net credit recognized as compensation expense related to restricted stock units was \$0.6 million for 2009. In 2008, compensation expense related to restricted stock units was \$1.4 million. As of June 30, 2009, the total unrecognized compensation cost related to unvested stock units was \$1.2 million and is expected to be recognized over a weighted average period of 2.3 years.

NOTE 19 — ENVIRONMENTAL MATTERS

The operation of our business has exposed us to certain liabilities and compliance costs related to environmental matters. We are involved in various environmental cleanup and remediation activities at certain of our locations.

Superfund Sites We are involved as a PRP at various sites designated by the USEPA as Superfund sites. With respect to the Li Tungsten Superfund site in Glen Cove, New York, we remitted \$0.9 million in 2008 to the DOJ as payment in full settlement for its claim against us for costs related to that site and reversed the remaining accrual of \$0.1 million to operating expense. For certain of these sites, we have evaluated the claims and potential liabilities and have determined that neither are material, individually or in the aggregate. For certain other sites, proceedings are in the very early stages and have not yet progressed to a point where it is possible to estimate the ultimate cost of remediation, the timing and extent of remedial action that may be required by governmental authorities or the amount of our liability alone or in relation to that of any other PRPs.

Other Environmental Issues We establish and maintain reserves for other potential environmental issues. At June 30, 2009 and 2008, the total of accruals for these reserves was \$5.3 million and \$6.2 million, respectively. These totals represent anticipated costs associated with the remediation of these issues. Cash payments of \$0.1 million and \$1.0 million were made against these reserves during 2009 and 2008, respectively. We recorded favorable foreign currency translation adjustments of \$0.7 million during 2009 related to these reserves. We recorded unfavorable foreign currency translation adjustments of \$0.8 million during 2008 related to these reserves. The reserves we have established for environmental liabilities represent our best current estimate of the costs of addressing all identified environmental situations, based on our review of currently available evidence, and take into consideration our prior experience in remediation and that of other companies, as well as public information released by the USEPA, other governmental agencies, and by the PRP groups in which we are participating. Although the reserves currently appear to be sufficient to cover these environmental liabilities, there are uncertainties associated with environmental liabilities, and we can give no assurance that our estimate of any environmental liability will not increase or decrease in the future. The reserved and unreserved liabilities for all environmental concerns could change substantially due to factors such as the nature and extent of contamination, changes in remedial requirements, technological changes, discovery of new information, the financial strength of other PRPs, the identification of new PRPs and the involvement of and direction taken by the government on these matters.

We maintain a Corporate EHS Department, as well as an EHS Steering Committee, to monitor compliance with environmental regulations and to oversee remediation activities. In addition, we have established an EHS coordinator at each of our global manufacturing facilities. Our financial management team periodically meets with members of the Corporate EHS Department and the Corporate Legal Department to review and evaluate the status of environmental projects and contingencies. On a quarterly basis, we review financial provisions and reserves for environmental contingencies and adjust these reserves when appropriate.

NOTE 20 — COMMITMENTS AND CONTINGENCIES

Legal Matters Various lawsuits arising during the normal course of business are pending against us. In our opinion, the ultimate liability, if any, resulting from these matters will have no significant effect on our consolidated financial positions or results of operations.

Lease Commitments We lease a wide variety of facilities and equipment under operating leases, primarily for warehouses, production and office facilities and equipment. Lease expense under these rentals amounted to \$30.9 million, \$30.5 million, and \$27.7 million in 2009, 2008 and 2007, respectively. Future minimum lease payments for non-cancelable operating leases are \$21.4 million, \$15.3 million, \$7.7 million, \$4.7 million and \$3.6 million for the years 2010 through 2014 and \$25.0 million thereafter.

Purchase Commitments We have purchase commitments for materials, supplies and machinery and equipment as part of the ordinary conduct of business. A few of these commitments extend beyond one year and are based on minimum purchase requirements. We believe these commitments are not at prices in excess of current market.

Other Contractual Obligations We do not have material financial guarantees or other contractual commitments that are reasonably likely to adversely affect our liquidity.

Related Party Transactions Sales to affiliated companies were immaterial in 2009 and 2008. Sales to affiliated companies were \$12.1 million in 2007. We do not have any other related party transactions that affect our operations, results of operations, cash flow or financial condition.

NOTE 21 — RIGHTS PLAN

Our shareowner rights plan provides for the distribution to shareowners of one-half of a right for each share of capital stock held as of September 5, 2000. See Note 2 for disclosure of our 2008 capital stock split. Each right entitles a shareowner to buy 1/100th of a share of a new series of preferred stock at a price of \$120 (subject to adjustment). The rights are exercisable only if a person or group of persons acquires or intends to make a tender offer for 20 percent or more of our capital stock. If any person acquires 20 percent of the capital stock, each right will entitle the other shareowners to receive that number of shares of capital stock having a market value of two times the exercise price. If we are acquired in a merger or other business combination, each right will entitle the shareowners to purchase at the exercise price that number of shares of the acquiring company having a market value of two times the exercise price. The rights will expire on November 2, 2010 and are subject to redemption at \$0.01 per right.

NOTE 22 — TREASURY SHARE RESTORATION

Effective January 22, 2008, our Board of Directors (the Board) resolved to restore all of the Company's treasury shares as of such date to unissued capital stock. The resolution also provided that, unless the Board resolves otherwise, any and all additional shares of capital stock acquired by the Company after such date will automatically be restored to unissued capital stock. Restoration of treasury shares was recorded as a reduction to capital stock of \$8.1 million and additional paid-in capital of \$202.5 million.

NOTE 23 — SEGMENT DATA

We operate in two global business units consisting of MSSG and AMMSG, and Corporate. The presentation of segment information reflects the manner in which we organize segments for making operating decisions and assessing performance.

Intersegment sales are accounted for at arm's-length prices, reflecting prevailing market conditions within the various geographic areas. Such sales and associated costs are eliminated in our consolidated financial statements.

Sales to a single customer did not aggregate 10 percent or more of total sales in 2009, 2008 or 2007. Export sales from U.S. operations to unaffiliated customers were \$116.6 million, \$113.6 million, and \$133.0 million in 2009, 2008 and 2007, respectively.

METALWORKING SOLUTIONS & SERVICES GROUP In the MSSG segment, we provide consumable metalcutting tools and tooling systems to manufacturing companies in a wide range of industries throughout the world. Metalcutting operations include turning, boring, threading, grooving, milling and drilling. Our tooling systems consist of a steel toolholder and cutting tool such as an indexable insert or drill made from cemented tungsten carbides, ceramics, cermets or other hard materials. During a metalworking operation, the toolholder is positioned in a machine that provides turning power. While the workpiece or toolholder is rapidly rotating, the cutting tool insert or drill contacts the workpiece and cuts or shapes the workpiece. The cutting tool insert or drill is consumed during use and must be replaced periodically. We also provide custom solutions to our customers' metalcutting needs through engineering services aimed at improving their competitiveness. Engineering services include field sales engineers identifying products that enhance productivity and engineering product designs to meet customer needs.

ADVANCED MATERIALS SOLUTIONS GROUP In the AMMSG segment, the principal business lines include the production and sale of cemented tungsten carbide products used in mining, highway construction and engineered applications requiring wear and corrosion resistance, including compacts and other similar applications. These products have technical commonality to our metalworking products. Additionally, we manufacture and market engineered components with a proprietary metal cladding technology as well as other hard materials that likewise provide wear resistance and life extension. These products include radial bearings used for directional drilling for oil and gas, extruder barrels used by plastics manufacturers and food processors and numerous other engineered components to service a wide variety of industrial markets. We also sell metallurgical powders to manufacturers of cemented tungsten carbide products, intermetallic composite ceramic powders and parts used in the metalized film industry, and we provide application-specific component design services and on-site application support services. Lastly, we provide our customers with engineered component process technology and materials, which focus on component deburring, polishing and producing controlled radii.

Segment data is summarized as follows:

(in thousands)	2009	2008	2007
External sales:			
MSSG	\$ 1,191,759	\$ 1,674,516	\$ 1,457,077
AMSG	808,100	915,270	808,259
Total external sales	\$ 1,999,859	\$ 2,589,786	\$ 2,265,336
Intersegment sales:			
MSSG	\$ 139,509	\$ 174,004	\$ 135,502
AMSG	17,805	39,131	42,881
Total intersegment sales	\$ 157,314	\$ 213,135	\$ 178,383
Total sales:			
MSSG	\$ 1,331,268	\$ 1,848,520	\$ 1,592,579
AMSG	825,905	954,401	851,140
Total sales	\$ 2,157,173	\$ 2,802,921	\$ 2,443,719
Operating (loss) income:			
MSSG	\$ (19,180)	\$ 255,391	\$ 217,706
AMSG	(39,539)	83,925	131,323
Corporate	(41,099)	(80,769)	(83,290)
Total operating (loss) income	\$ (99,818)	\$ 258,547	\$ 265,739
Interest expense	27,244	31,586	28,999
Other income, net	(14,566)	(2,439)	(8,413)
(Loss) income from continuing operations before income taxes and minority interest expense	\$ (112,496)	\$ 229,400	\$ 245,153

Segment data (continued):

(in thousands)	2009	2008	2007
Depreciation and amortization			
MSSG	\$ 63,496	\$ 62,574	\$ 50,110
AMSG	25,022	23,762	20,217
Corporate	7,863	8,397	8,336
Total depreciation and amortization	\$ 96,381	\$ 94,733	\$ 78,663
Equity (loss) income:			
MSSG	\$ (3)	\$ 196	\$ 2,638
AMSG	2	30	185
Total equity (loss) income	\$ (1)	\$ 226	\$ 2,823
Total assets:			
MSSG	\$ 1,269,594	\$ 1,586,731	\$ 1,493,891
AMSG	766,465	932,110	894,886
Corporate	310,915	265,508	217,450
Total assets	\$ 2,346,974	\$ 2,784,349	\$ 2,606,227
Capital expenditures:			
MSSG	\$ 73,102	\$ 131,171	\$ 60,246
AMSG	24,864	26,794	23,459
Corporate	6,876	5,524	8,296
Total capital expenditures	\$ 104,842	\$ 163,489	\$ 92,001
Investments in affiliated companies:			
MSSG	\$ 298	\$ 408	\$ 2,480
AMSG	1,840	1,917	1,444
Total investments in affiliated companies	\$ 2,138	\$ 2,325	\$ 3,924

Geographic information for sales, based on country of origin, and assets is as follows:

(in thousands)	2009	2008	2007
External sales:			
United States	\$ 907,967	\$ 1,092,102	\$ 1,038,888
Germany	360,560	531,376	441,113
Asia	266,676	321,310	252,388
United Kingdom	59,749	82,120	72,468
Canada	47,348	71,109	75,319
Other	357,559	491,769	385,160
Total external sales	\$ 1,999,859	\$ 2,589,786	\$ 2,265,336
Total assets:			
United States	\$ 1,153,109	\$ 1,269,774	\$ 1,343,430
Germany	371,394	455,302	389,933
Asia	302,355	342,317	273,715
United Kingdom	41,233	66,391	73,334
Canada	28,055	43,319	42,722
Other	450,828	607,246	483,093
Total assets:	\$ 2,346,974	\$ 2,784,349	\$ 2,606,227

NOTE 24 – SUBSEQUENT EVENTS

In connection with the preparation of the consolidated financial statements and in accordance with the recently issued SFAS No. 165, “Subsequent Events,” we evaluated subsequent events after the balance sheet date of June 30, 2009 through August 13, 2009, the date prior to the issuance of the financial statements.

On July 6, 2009, we entered into an amendment to our 2006 Credit Agreement. The amendment provides for the exclusion of certain cash restructuring charges from the earnings component used in the calculation of the leverage and interest ratios. The amendment also provides for an increase in the permitted leverage ratio for certain quarterly measurement dates. The amendment also provides restrictions on share repurchases and securitizations, as well as future acquisitions and capital leases should leverage ratios exceed the permitted ratio that prevailed prior to the amendment. Furthermore, the amendment would require security interest in our domestic accounts receivable and inventories should our leverage ratio exceed a certain threshold. The amendment includes an increase in interest rates on borrowings of approximately 200 basis points.

Also, during July 2009, we completed the issuance of 8.1 million shares of common stock generating net proceeds of \$120.3 million which were used to pay down outstanding indebtedness under our revolving credit facility.

NOTE 25 – SELECTED QUARTERLY FINANCIAL DATA (unaudited)

For the quarter ended (in thousands, except per share data)	September 30	December 31	March 31	June 30
2009				
Sales	\$ 643,374	\$ 546,061	\$ 424,387	\$ 386,037
Gross profit	215,120	160,162	102,428	98,829
Income (loss) from continuing operations ^a	35,012	15,687	(137,282)	(15,819)
Net income (loss) ^a	35,467	15,659	(137,875)	(32,993)
Basic earnings (loss) per share ^b				
Continuing operations	0.47	0.22	(1.89)	(0.21)
Net income (loss)	0.48	0.22	(1.90)	(0.45)
Diluted earnings (loss) per share ^b				
Continuing operations	0.46	0.21	(1.89)	(0.21)
Net income (loss)	0.47	0.21	(1.90)	(0.45)
2008				
Sales	\$ 585,522	\$ 618,301	\$ 662,012	\$ 723,951
Gross profit	208,232	217,901	233,176	247,762
Income from continuing operations ^a	34,008	49,711	21,719	58,228
Net income ^a	34,879	50,146	23,170	59,580
Basic earnings per share ^{b, c}				
Continuing operations	0.44	0.64	0.28	0.76
Net income	0.45	0.65	0.30	0.78
Diluted earnings per share ^{b, c}				
Continuing operations	0.43	0.63	0.28	0.75
Net income	0.44	0.64	0.30	0.77

a) Loss from continuing operations and net loss for the quarter ended June 30, 2009 includes restructuring charges of \$16.2 million. Loss from continuing operations and net loss for the quarter ended March 31, 2009 includes restructuring and asset impairment charges of \$142.9 million. Income from continuing operations and net income for quarter ended September 30 and December 31, 2008, includes restructuring charges of \$8.4 million and \$6.2 million. Income from continuing operations and net income for the quarter ended March 31, 2008 include a goodwill impairment charge of \$35.0 million. For the quarter ended June 30, 2008, income from continuing operations and net income include restructuring charges of \$4.9 million.

b) Earnings per share amounts for each quarter are computed using the weighted average number of shares outstanding during the quarter. Earnings per share amounts for the full year are computed using the weighted average number of shares outstanding during the year. Thus, the sum of the four quarters' earnings per share does not always equal the full-year earnings per share.

c) Per share amounts have been restated to reflect the Company's 2-for-1 stock split completed in December 2007. See Note 2 for additional information.

ITEM 9 — CHANGES IN AND DISAGREEMENTS WITH ACCOUNTANTS ON ACCOUNTING AND FINANCIAL DISCLOSURE

None.

ITEM 9A — CONTROLS AND PROCEDURES

(a) Evaluation of Disclosure Controls and Procedures

The Company's management evaluated, with the participation of the Company's Chief Executive Officer and Chief Financial Officer, the effectiveness of the Company's disclosure controls and procedures (as defined in Exchange Act Rules 13a-15(e) and 15d-15(e)). The Company's disclosure controls were designed to provide a reasonable assurance that information required to be disclosed in reports that we file or submit under the Securities Exchange Act of 1934, as amended (Exchange Act), is recorded, processed, summarized and reported within the time periods specified in the rules and forms of the Securities and Exchange Commission. It should be noted that the design of any system of controls is based in part upon certain assumptions about the likelihood of future events, and there can be no assurance that any design will succeed in achieving its stated goals under all potential future conditions, regardless of how remote. However, the controls have been designed to provide reasonable assurance of achieving the controls' stated goals. Based on that evaluation, the Company's Chief Executive Officer and Chief Financial Officer have concluded that the Company's disclosure controls and procedures are effective to provide reasonable assurance at June 30, 2009 to ensure that information required to be disclosed in the reports that we file or submit under the Exchange Act is (i) accumulated and communicated to management, including the Company's Chief Executive Officer and Chief Financial Officer, to allow timely decisions regarding required disclosure and (ii) recorded, processed, summarized and reported within the time periods specified in the rules and forms of the Securities and Exchange Commission.

(b) Management's Report on Internal Control over Financial Reporting

Management's Report on Internal Control over Financial Reporting is included in Item 8 of this Form 10-K and incorporated here by reference.

(c) Attestation Report of the Independent Registered Public Accounting Firm

The effectiveness of Kennametal's internal control over financial reporting as of June 30, 2009 has been audited by PricewaterhouseCoopers LLP, an independent registered public accounting firm, as stated in their report included in Item 8 of this Form 10-K.

(d) Changes in Internal Control over Financial Reporting

There have been no changes in internal control over financial reporting that occurred during the fourth quarter of 2009 that have materially affected, or are reasonably likely to materially affect, the Company's internal control over financial reporting.

ITEM 9B — OTHER INFORMATION

None.

Part III

ITEM 10 — DIRECTORS, EXECUTIVE OFFICERS AND CORPORATE GOVERNANCE

EXECUTIVE OFFICERS OF THE REGISTRANT

Information regarding the executive officers of Kennametal Inc. is as follows: Name, Age and Position, and Experience During the Past Five Years ⁽¹⁾.

Carlos M. Cardoso, 51

Chairman of the Board, President and Chief Executive Officer

Chairman of the Board of Directors since January 2008; President and Chief Executive Officer since January 2006; Executive Vice President and Chief Operating Officer from January 2005 to December 2005; Vice President and President, Metalworking Solutions and Services Group from April 2003 to December 2004.

Paul J. DeMand, 44

Vice President and President, Metalworking Solutions & Services Group

Vice President and President, Metalworking Solutions & Services Group since July 2008. Formerly, Senior Vice President/Division Head of the Industrial Products Group at Johnson Electric, Ltd., Hong Kong (a manufacturer of engineered components and motion systems) from September 2003 to April 2008.

David W. Greenfield, 59

Vice President, Secretary and General Counsel

Vice President, Secretary and General Counsel since October 2001.

Steven R. Hanna, 55

Vice President and Chief Information Officer

Vice President and Chief Information Officer since October 2008. Formerly, Corporate Information Officer at General Motors Corporation from May 1998 to September 2008.

John H. Jacko, Jr., 52

Vice President and Chief Marketing Officer

Vice President and Chief Marketing Officer since July 2008; Vice President Corporate Strategy and MSSG Global Marketing from March 2007 to July 2008. Formerly, Vice President, Chief Marketing Officer at Flowserve Corporation (a manufacturer / provider of flow management products and services) from November 2002 to February 2007.

Lawrence J. Lanza, 60

Vice President and Treasurer

Vice President since October 2006; Treasurer since July 2003.

James E. Morrison, 58

Vice President Mergers and Acquisitions

Vice President since 1994; Vice President, Mergers and Acquisitions since July 2003.

Wayne D. Moser, 56

Vice President Finance and Corporate Controller

Vice President Finance and Corporate Controller since December 2006; Chief Financial Officer - Europe from August 2005 to December 2006; Director, European Strategic Initiatives from November 2004 to July 2005; General Manager, Industrial Products Europe from July 2003 to October 2004.

Frank P. Simpkins, 46

Vice President and Chief Financial Officer

Vice President and Chief Financial Officer since December 2006; Vice President Finance and Corporate Controller from February 2006 to December 2006; Vice President of Global Finance of Kennametal Industrial Business from October 2005 to February 2006; Director of Finance, Metalworking Solutions & Services Group from February 2002 to February 2006.

John R. Tucker, 62

Vice President and Chief Technical Officer

Vice President and Chief Technical Officer since October 2008. Formerly, Chairman and Chief Executive Officer of Sermatech International (a developer of engineered protective coatings) from August 2006 to May 2008; President and Chief Executive Officer of Capstone Turbine Corporation (a producer of low-emission microturbine systems) from August 2003 to July 2006.

Kevin R. Walling, 44

Vice President and Chief Human Resources Officer

Vice President and Chief Human Resources Officer since November 2005; Vice President, Metalworking Solutions and Services Group from February 2005 to November 2005. Formerly, Vice President Human Resources, North America of Marconi Corporation (a communications company) from February 2001 to January 2005.

Philip H. Wehl, 53

Vice President Kennametal Value Business System (KVBS) and Lean Enterprise

Vice President Kennametal Value Business System (KVBS) and Lean Enterprise since January 2005; Vice President, Global Manufacturing from September 2001 through January 2005.

Gary W. Weismann, 54

Vice President and President, Advanced Materials Solutions Group

Vice President and President, Advanced Materials Solutions Group since August 2007; Vice President, Energy, Mining and Construction Solutions Group from March 2006 to July 2007; Vice President and General Manager, Electronics Products Group from January 2004 to March 2006.

1) Each executive officer has been elected by the Board of Directors to serve until removed or until a successor is elected and qualified.

Incorporated herein by reference is the information under the captions “Election of Directors” and “Section 16(a) Beneficial Ownership Reporting Compliance” in our definitive proxy statement to be filed with the Securities and Exchange Commission within 120 days after June 30, 2009 (2009 Proxy Statement).

Incorporated herein by reference is the information set forth under the caption “Ethics and Corporate Governance-Code of Business Ethics and Conduct” in the 2009 Proxy Statement.

The Company has a separately designated standing audit committee established in accordance with Section 3(a)(58)(A) of the Securities Exchange Act of 1934, as amended. The members of the Audit Committee are: Lawrence W. Stranghoener (Chair); A. Peter Held; Timothy R. McLevish; and Steven H. Wunning. Incorporated herein by reference is the information set forth in the second and third sentences under the caption “Board of Directors and Board Committees-Committee Functions-Audit Committee” in the 2009 Proxy Statement.

ITEM 11 — EXECUTIVE COMPENSATION

Incorporated herein by reference is the information set forth under the captions “Executive Compensation” and “Executive Compensation Tables” and certain information regarding directors’ compensation under the caption “Board of Directors and Board Committees - Board of Directors Compensation and Benefits” in the 2009 Proxy Statement.

ITEM 12 — SECURITY OWNERSHIP OF CERTAIN BENEFICIAL OWNERS AND MANAGEMENT AND RELATED SHAREOWNER MATTERS

Incorporated herein by reference is: (i) the information set forth under the caption “Equity Compensation Plans” and the related tabular disclosure under the table entitled “Equity Compensation Plan Information;” (ii) the information set forth under the caption “Ownership of Capital Stock by Directors, Nominees and Executive Officers” with respect to the directors’ and officers’ shareholdings; and (iii) the information set forth under the caption “Principal Holders of Voting Securities” with respect to other beneficial owners, each in the 2009 Proxy Statement.

ITEM 13 — CERTAIN RELATIONSHIPS AND RELATED TRANSACTIONS, AND DIRECTOR INDEPENDENCE

Incorporated herein by reference is certain information set forth in under the captions “Ethics and Corporate Governance - Corporate Governance Guidelines,” “Executive Compensation” and “Executive Compensation Tables” in the 2009 Proxy Statement.

ITEM 14 — PRINCIPAL ACCOUNTANT FEES AND SERVICES

Incorporated herein by reference is the information with respect to pre-approval policies set forth under the caption “Independent Registered Public Accounting Firm - Ratification of the Selection of the Independent Registered Public Accounting Firm - Audit Committee Pre-Approval Policy” and the information with respect to principal accountant fees and services set forth under “Independent Registered Public Accounting Firm - Ratification of the Selection of the Independent Registered Public Accounting Firm - Fees and Services” in the 2009 Proxy Statement.

Part IV

ITEM 15 — EXHIBITS, FINANCIAL STATEMENT SCHEDULES

(a) Documents filed as part of this Form 10-K report.

1. Financial Statements included in Part II, Item 8
2. Financial Statement Schedule

The financial statement schedule required by Part II, Item 8 of this document is filed as part of this report. All of the other schedules are omitted as the required information is inapplicable or the information is presented in our consolidated financial statements or related notes.

FINANCIAL STATEMENT SCHEDULE:

Schedule II—Valuation and Qualifying Accounts and Reserves for the Years Ended June 30, 2009, 2008 and 2007 Page
71

3. Exhibits

- | | | |
|------------|---|--|
| (2) | Plan of Acquisition, Reorganization, Arrangement, Liquidation or Succession | |
| (2.1) | Stock Purchase Agreement by and among JLK Direct Distribution, Inc., Kennametal Inc., MSC Industrial Direct Co., Inc. and MSC Acquisition Corp. VI dated as of March 15, 2006. | Exhibit 2.1 of the Form 8-K filed March 16, 2006 is incorporated herein by reference |
| (3) | Articles of Incorporation and Bylaws | |
| (3.1) | Amended and Restated Articles of Incorporation as amended through October 30, 2006 | Exhibit 3.1 of the December 31, 2006 Form 10-Q filed February 9, 2007 is incorporated herein by reference. |
| (3.2) | Bylaws of Kennametal Inc. as amended through May 8, 2007 | Exhibit 3.1 of March 31, 2007 Form 10-Q filed May 9, 2007 is incorporated herein by reference. |
| (4) | Instruments Defining the Rights of Security Holders, Including Indentures | |
| (4.1) | Rights Agreement effective as of November 2, 2000 | Exhibit 1 of the Form 8-A dated October 10, 2000 is incorporated herein by reference. |
| (4.2) | First Amendment to Rights Agreement, made and entered into as of October 6, 2004, by and between the Registrant and Mellon Investor Services LLC (now BNY Mellon Shareowner Services) | Exhibit 4.1 of the Form 8-K filed October 6, 2004 is incorporated herein by reference. |
| (4.3) | Indenture, dated as of June 19, 2002, by and between the Registrant and Bank One Trust Company, N.A., as trustee | Exhibit 4.1 of the Form 8-K filed June 20, 2002 is incorporated herein by reference. |
| (4.4) | First Supplemental Indenture, dated as of June 19, 2002, by and between the Registrant and Bank One Trust Company, N.A., as trustee | Exhibit 4.2 of the Form 8-K filed June 20, 2002 is incorporated herein by reference. |

(10) Material Contracts

- (10.1)* Kennametal Inc. Management Performance Bonus Plan Appendix A to the 2005 Proxy Statement filed September 26, 2005 is incorporated herein by reference.
- (10.2)* Deferred Fee Plan for Outside Directors, as amended and restated effective December 30, 2008 Exhibit 10.1 of the December 31, 2008 Form 10-Q filed February 4, 2009 is incorporated herein by reference.
- (10.3)* Executive Deferred Compensation Trust Agreement Exhibit 10.5 of the June 30, 1988 Form 10-K (SEC file no. reference 1-5318; docket entry date—September 23, 1988) is incorporated herein by reference.
- (10.4)* Directors Stock Incentive Plan, as amended and restated effective December 30, 2008 Exhibit 10.2 of the December 31, 2008 Form 10-Q filed February 4, 2009 is incorporated herein by reference.
- (10.5)* Stock Option and Incentive Plan of 1992, as amended Exhibit 10.8 of the December 31, 1996 Form 10-Q filed February 13, 1997 is incorporated herein by reference.
- (10.6)* Performance Bonus Stock Plan of 1995, as amended and restated effective December 30, 2008 Exhibit 10.3 of the December 31, 2008 Form 10-Q filed February 4, 2009 is incorporated herein by reference.
- (10.7)* Stock Option and Incentive Plan of 1996 Exhibit 10.14 of the September 30, 1996 Form 10-Q filed November 13, 1996 is incorporated herein by reference.
- (10.8)* Kennametal Inc. 1999 Stock Plan Exhibit 10.5 of the Form 8-K filed June 11, 1999 is incorporated herein by reference.
- (10.9)* Kennametal Inc. Stock Option and Incentive Plan of 1999 Exhibit A of the 1999 Proxy Statement filed September 20, 1999 is incorporated herein by reference.
- (10.10)* Kennametal Inc. Stock and Incentive Plan of 2002 (as amended on October 21, 2008) Appendix A to the 2008 Proxy Statement filed September 8, 2008 is incorporated herein by reference.
- (10.11)* Forms of Award Agreements under the Kennametal Inc. Stock and Incentive Plan of 2002 Exhibit 10.18 of the June 30, 2004 Form 10-K filed September 10, 2004 is incorporated herein by reference.
- (10.12)* Kennametal Inc. 2008 Strategic Transformational Equity Program Exhibit 10.2 of the December 31, 2007 Form 10-Q filed February 7, 2008 is incorporated herein by reference.
- (10.13)* Form of Award Agreement under the Kennametal Inc. 2008 Strategic Transformational Equity Program Exhibit 10.3 of the December 31, 2007 Form 10-Q filed February 7, 2008 is incorporated herein by reference.
- (10.14)* Form of Employment Agreement with Carlos M. Cardoso Exhibit 10.9 of the June 30, 2000 Form 10-K filed September 22, 2000 is incorporated herein by reference.
- (10.15)* Letter Agreement amending Employment Agreement with Carlos M. Cardoso Exhibit 10.2 of the Form 8-K filed December 9, 2005 is incorporated herein by reference.
- (10.16)* Amendment No. 3 to Employment Agreement with Carlos M. Cardoso Exhibit 10.5 of the December 31, 2008 Form 10-Q filed February 4, 2009 is incorporated herein by reference.
- (10.17)* Form of Amended and Restated Employment Agreement with Named Executive Officers (other than Mr. Cardoso) Exhibit 10.1 of the December 31, 2006 Form 10-Q filed February 9, 2007 is incorporated herein by reference.
- (10.18)* Form of Amendment to Amended and Restated Employment Agreement with Named Executive Officers (other than Mr. Cardoso) Exhibit 10.6 of the December 31, 2008 Form 10-Q filed February 4, 2009 is incorporated herein by reference.
- (10.19)* Schedule of Named Executive Officers who have entered into the Form of Amended and Restated Employment Agreement and Form of Amendment as set forth in Exhibits 10.17 and 10.18 Exhibit 10.7 of the December 31, 2008 Form 10-Q filed February 4, 2009 is incorporated herein by reference.
- (10.20)* Form of Indemnification Agreement for Named Executive Officers Exhibit 10.2 of the Form 8-K filed March 22, 2005 is incorporated herein by reference.
- (10.21)* Schedule of Named Executive Officers who have entered into the Form of Indemnification Agreement as set forth in Exhibit 10.20 Exhibit 10.19 of the June 30, 2008 Form 10-K filed August 14, 2008 is incorporated herein by reference.
- (10.22)* Kennametal Inc. 2006 Executive Retirement Plan (for Designated Others) (as amended effective December 30, 2008) Exhibit 10.8 of the December 31, 2008 Form 10-Q filed February 4, 2009 is incorporated herein by reference.

(10.23)*	Kennametal Inc. Supplemental Executive Retirement Plan (as amended effective December 30, 2008)	Exhibit 10.9 of the December 31, 2008 Form 10-Q filed February 4, 2009 is incorporated herein by reference.
(10.24)*	Letter Agreement dated December 6, 2006 by and between Kennametal Inc. and Frank P. Simpkins	Exhibit 10.3 of the December 31, 2006 Form 10-Q filed February 9, 2007 is incorporated herein by reference.
(10.25)*	Description of Compensation Payable to Non-Employee Directors	Exhibit 10.23 from the June 30, 2008 Form 10-K filed August 14, 2008 is incorporated herein by reference.
(10.26)*	Summary of Perquisites Program	The text of Item 1.01 of the Form 8-K filed April 28, 2005 is incorporated herein by reference.
(10.27)*	Summary of Salary Reductions	The text of Item 5.02 of the Form 8-K filed June 26, 2009 is incorporated herein by reference.
(10.28)	Second Amended and Restated Credit Agreement dated as of March 21, 2006 among Kennametal Inc., Kennametal Europe GmbH, Bank of America, N.A. (as Administrative Agent); Keybank National Association and National City Bank of Pennsylvania (as Co-Syndication Agents); PNC Bank, National Association and JPMorgan Chase Bank, N.A. (as Co-Documentation Agents); and the following lenders: Bank of America, N.A., Bank of America, N.A., London Branch, Keybank National Association, National City Bank of Pennsylvania, PNC Bank, National Association, JPMorgan Chase Bank, N.A., Bank of Tokyo-Mitsubishi UFJ Trust Company, Citizens Bank of Pennsylvania, Comerica Bank, The Bank of New York, Mizuho Corporate Bank, Ltd., Fifth Third Bank, LaSalle Bank National Association, Sanpaolo IMI and Chiao Tung Bank Co., Ltd.	Exhibit 10.1 of Form 8-K filed March 27, 2006 is incorporated herein by reference.
(10.29)	Form of Second Amended and Restated Guarantee (in connection with the Second Amended and Restated Credit Agreement set forth in Exhibit 10.28)	Filed herewith.
(10.30)	Amendment Number 1 to the Second Amended and Restated Credit Agreement dated as of July 6, 2009	Exhibit 10.1 of the Form 8-K filed July 6, 2009 is incorporated herein by reference.
(21)	Subsidiaries of the Registrant	Filed herewith.
(23)	Consent of Independent Registered Public Accounting Firm	Filed herewith.
(31)	Certifications	
(31.1)	Certification executed by Carlos M. Cardoso, Chairman, President and Chief Executive Officer of Kennametal Inc.	Filed herewith.
(31.2)	Certification executed by Frank P. Simpkins, Vice President and Chief Financial Officer of Kennametal Inc.	Filed herewith.
(32)	Section 1350 Certifications	
(32.1)	Certification Pursuant to 18 U.S.C. Section 1350 as Adopted Pursuant to Section 906 of the Sarbanes-Oxley Act of 2002, executed by Carlos M. Cardoso, Chairman, President and Chief Executive Officer of Kennametal Inc., and Frank P. Simpkins, Vice President and Chief Financial Officer of Kennametal Inc.	Filed herewith.

* Denotes management contract or compensatory plan or arrangement.

SIGNATURES

Pursuant to the requirements of the Securities Exchange Act of 1934, the registrant has duly caused this report to be signed on its behalf by the undersigned thereunto duly authorized.

Date: August 14, 2009

KENNAMETAL INC.

By: /s/ Wayne D. Moser

Wayne D. Moser

Vice President Finance and Corporate Controller

Pursuant to the requirements of the Securities Exchange Act of 1934, this report has been signed below by the following persons on behalf of the registrant and in the capacities and on the dates indicated.

SIGNATURE	TITLE	DATE
<u>/s/ CARLOS M. CARDOSO</u> Carlos M. Cardoso	Chairman, President and Chief Executive Officer	August 12, 2009
<u>/s/ FRANK P. SIMPKINS</u> Frank P. Simpkins	Vice President and Chief Financial Officer	August 12, 2009
<u>/s/ WAYNE D. MOSER</u> Wayne D. Moser	Vice President Finance and Corporate Controller	August 12, 2009
<u>/s/ RONALD M. DEFEO</u> Ronald M. DeFeo	Director	August 12, 2009
<u>/s/ PHILIP A. DUR</u> Philip A. Dur	Director	August 12, 2009
<u>/s/ A. PETER HELD</u> A. Peter Held	Director	August 12, 2009
<u>/s/ TIMOTHY R. MCLEVISH</u> Timothy R. McLevish	Director	August 12, 2009
<u>/s/ WILLIAM R. NEWLIN</u> William R. Newlin	Director	August 12, 2009
<u>/s/ LAWRENCE W. STRANGHOENER</u> Lawrence W. Stranghoener	Director	August 12, 2009
<u>/s/ STEVEN H. WUNNING</u> Steven H. Wunning	Director	August 12, 2009
<u>/s/ LARRY D. YOST</u> Larry D. Yost	Director	August 12, 2009

SCHEDULE II — VALUATION AND QUALIFYING ACCOUNTS AND RESERVES

(In thousands) For the year ended June 30	Balance at Beginning of Year	Charged to Costs and Expenses	Charged to Other Comprehensive Income	Recoveries	Other Adjustments	Deductions from Reserves	Balance at End of Year
2009							
Allowance for doubtful accounts	\$ 18,473	\$ 9,597	\$ -	\$ 856	\$ 1,566 ^a	\$ 5,264 ^b	\$ 25,228
Reserve for obsolete inventory	61,470	22,730	-	-	(14,164) ^a	8,913 ^c	61,123
Deferred tax asset valuation allowance	46,650	2,490	4,572	-	(5,506) ^a	-	48,206
2008							
Allowance for doubtful accounts	\$ 17,031	\$ 2,111	\$ -	\$ 499	\$ 4,502 ^a	\$ 5,670 ^b	\$ 18,473
Reserve for obsolete inventory	59,706	9,391	-	-	5,065 ^a	12,692 ^c	61,470
Deferred tax asset valuation allowance	45,150	155	1,193	(2,447)	2,599 ^a	-	46,650
2007							
Allowance for doubtful accounts	\$ 14,692	\$ 1,270	\$ -	\$ 299	\$ 3,059 ^a	\$ 2,289 ^b	\$ 17,031
Reserve for obsolete inventory	56,104	4,771	-	-	3,375 ^a	4,544 ^c	59,706
Deferred tax asset valuation allowance	38,744	703	-	-	6,812 ^{a d}	1,109 ^e	45,150

a) Represents foreign currency translation adjustment and reserves divested or acquired through business combinations.

b) Represents uncollected accounts charged against the allowance.

c) Represents scrapped inventory and other charges against the reserve.

d) Includes the impact of adoption of SFAS 158.

e) Represents a reduction in the allowance due to a reduction in the underlying deferred tax assets.

CORPORATE DIRECTORY

Our consolidated subsidiaries and affiliated companies as of June 30, 2009 are:

Consolidated Subsidiaries of Kennametal Inc.

Kennametal Australia Pty. Ltd.
 Kennametal Distribution Services Asia Pte. Ltd.
 Kennametal Exports Inc.
 Kennametal (Shanghai) Ltd.
 Kennametal (Thailand) Co., Ltd.
 Kennametal International S.A. (Panama)
 Kennametal Japan Ltd.
 Kennametal (Malaysia) Sdn. Bhd.
 Kennametal de Mexico, S.A. de C.V.
 Kennametal Sp. Z.o.o
 Kennametal (Singapore) Pte. Ltd.
 Kennametal South Africa (Pty.) Ltd.
 Kennametal Korea Ltd.
 Kennametal Holding (Cayman Islands) Ltd.
 Kennametal Hungary Holdings Inc.
 Kennametal Hungary Finance Services Kft.
 Kennametal Financing I Corp.
 Kennametal Holdings Europe Inc.
 Carbidie Asia Pacific Pte. Ltd.
 Cleveland Twist Drill de Mexico, S.A. de C.V.
 Kennametal Extrude Hone Corporation
 Hanita Metal Works, Ltd.
 Kennametal Sintec Holding GmbH
 Kennametal Luxembourg S.a.r.l.
 Kennametal Tricon Metals & Services, Inc.
 Kennametal Shared Services Private Limited
 Kennametal Hardpoint (Taiwan) Inc.
 Powdermet, Inc.
 ISIS GHH Limited

Consolidated Subsidiaries of Kennametal Luxembourg S.a.r.l.

Kennametal Ltd.
 Kennametal Asia (HK) Ltd.

Consolidated Subsidiary of Kennametal Ltd

Camco Cutting Tools Ltd.

Consolidated Subsidiary of Kennametal Holdings Europe Inc.

Kennametal Widia Holdings Inc.

Consolidated Subsidiaries and Affiliated Company of Kennametal Widia Holdings Inc.

Kennametal Europe Holding GmbH
 Kennametal Verwaltungs GmbH & Co. Kg (partnership)
 ISIS Informatics Limited

Consolidated Affiliated Companies of Kennametal Europe Holding GmbH

Kennametal Europe L.P. (partnership)
 Kennametal Europe Holding GmbH, Niederlassung Deutschland

Consolidated Subsidiary of Kennametal Europe L.P.

Kennametal Europe GmbH

Consolidated Subsidiaries of Kennametal Europe GmbH

Kennametal Holding GmbH
OOO Kennametal

Consolidated Subsidiaries of Kennametal Holding GmbH (Germany)

Kennametal Hertel Europe Holding GmbH
Kennametal Widia Beteiligungs GmbH

Consolidated Subsidiaries of Kennametal Hertel Europe Holding GmbH

Kennametal GmbH
Kennametal AMSG GmbH
Kennametal Hungaria Kft.
Kennametal Logistics GmbH
Kennametal Shared Services GmbH
Kennametal Technologies GmbH
Kemmer CIRBO S.r.l. (Italy)
Kennametal Sintec Keramik (U.K.) Ltd.
Kennametal Sintec Keramik GmbH
Kennametal HTM AG
Widia GmbH

Consolidated Subsidiaries and Affiliated Companies of Kennametal GmbH

Kennametal Belgium S.p.r.l.
Kennametal Czech s.r.o.
Kennametal Deutschland GmbH
Kennametal France S.A.S
Kennametal Italia S.p.A.
Kennametal Kesici Takimlar Sanayi ve Ticaret A.S. (Turkey)
Kennametal Nederland B.V.
Kennametal Oesterreich GmbH
Kennametal Produktions GmbH & Co. KG. (partnership)
Kennametal Produktions Services GmbH
Kennametal Real Estate Beteiligungs GmbH
Kennametal U.K. Limited
Kenci SL
Ruebig Real Estate GmbH & Co. KG

Consolidated Affiliated Company of Kennametal Produktions GmbH & Co. KG (partnership)

Kennametal Real Estate GmbH & Co. KG (partnership)

Consolidated Affiliated Company of Kennametal Deutschland GmbH

Kennametal (Deutschland) Real Estate GmbH & Co. KG (partnership)

Consolidated Subsidiary of ISIS Informatics Limited

International Twist Drill Limited

Consolidated Subsidiaries of Kennametal Asia (HK) Ltd.

Kennametal Hardpoint Shanghai Co., Ltd.
Kennametal (China) Co. Ltd.
Kennametal (Xuzhou) Company, Ltd.

Consolidated Subsidiaries and Affiliated Companies of Widia GmbH

Kennametal Widia Real Estate GmbH & Co. KG (partnership)
Kennametal Widia Produktions GmbH & Co. KG (partnership)
Meturit AG

Consolidated Subsidiary of Meturit AG
Kennametal India Ltd.

Consolidated Subsidiaries of Kennametal Holding (Cayman Islands) Ltd.
Kennametal Argentina S.A.
Kennametal do Brasil Ltda.
Kennametal Chile Ltda.

Consolidated Subsidiaries of Kenci SL
Kennametal Manufacturing Spain S.L.
Kenci LDA
Kennametal Manufacturing Barcelona SL
Kenem SL

Consolidated Subsidiary of Kennametal Oesterreich GmbH
Kennametal Polska Sp. Z.o.o.

Consolidated Subsidiaries of Kennametal U.K. Ltd.
Kennametal Logistics U.K. Ltd.
Kennametal Manufacturing U.K. Ltd.

Consolidated Subsidiary of Kennametal France S.A.S.
Kennametal Production France S.A.R.L.

Consolidated Subsidiary of Kennametal Nederland B.V.
Kennametal Engineered Products B.V.

Consolidated Subsidiaries of Kennametal Extrude Hone Corporation
Extrude Hone Korea Co. Ltd.
Kennametal Extrude Hone Ltd.
Kennametal Extrude Hone Limited
Extrude Hone Participacoes Ltda.
Extrude Hone Shanghai, Co. Ltd.

Consolidated Subsidiaries and Affiliated Company of Kennametal Extrude Hone Ltd.
Extrude Hone Holding GmbH
Extrude Hone France S.A.
Extrude Hone KK (Japan)
Extrude Hone Spain (SC)
Kennametal Extrude Hone GmbH & Co. KG (partnership)
Extrude Hone (Ireland) Limited

Consolidated Subsidiaries of Extrude Hone Holding GmbH
Kennametal Extrude Hone GmbH
Kennametal Extrude Hone Czech s.r.o

Consolidated Subsidiary of Extrude Hone Participacoes Ltda.
Extrude Hone do Brasil Sistemas De Acabamentos De Peca Ltda.

Consolidated Subsidiaries of Hanita Metal Works, Ltd.
Hanita Cutting Tools, Inc.

Consolidated Subsidiary of Cleveland Twist Drill de Mexico, S.A. de C.V.
Greenfield Tools de Mexico, S.A. de C.V.

Consolidated Subsidiary of Kennametal Sintec Keramik Asia Ltd.
Sunshine Powder Technology Co., Ltd.

Consolidated Subsidiaries of Kennametal Sintec Holding GmbH
Kennametal Sintec Ceramic Shanghai Co., Ltd.
Kennametal Sintec Keramik Asia Ltd.

Consent of Independent Registered Public Accounting Firm

We hereby consent to the incorporation by reference in the Registration Statements on Form S-8 (No. 33-55768, No. 33-55766, No. 33-65023, No. 333-18423, No. 333-18429, No. 333-18437, No. 333-77411, No. 333-88049, No. 333-30454, No. 333-30448, No. 333-53562, No. 333-100867, No. 333-120314, No. 333-124774, No. 333-142727, No. 333-154705) and Form S-3 (No. 333-40809, No. 333-154703, No. 333-160474) of Kennametal Inc. of our report dated August 12, 2009 relating to the financial statements, financial statement schedule and the effectiveness of internal control over financial reporting, which appears in this Form 10-K.

/s/ PricewaterhouseCoopers LLP
PricewaterhouseCoopers LLP
Pittsburgh, Pennsylvania
August 14, 2009

I, Carlos M. Cardoso, certify that:

1. I have reviewed this annual report on Form 10-K of Kennametal Inc.;
2. Based on my knowledge, this report does not contain any untrue statement of a material fact or omit to state a material fact necessary to make the statements made, in light of the circumstances under which such statements were made, not misleading with respect to the period covered by this report;
3. Based on my knowledge, the financial statements, and other financial information included in this report, fairly present in all material respects the financial condition, results of operations and cash flows of the registrant as of, and for, the periods presented in this report;
4. The registrant's other certifying officer and I are responsible for establishing and maintaining disclosure controls and procedures (as defined in Exchange Act Rules 13a-15(e) and 15d-15(e)) and internal control over financial reporting (as defined in Exchange Act Rules 13a-15(f) and 15d-15(f)) for the registrant and have:
 - a) Designed such disclosure controls and procedures, or caused such disclosure controls and procedures to be designed under our supervision, to ensure that material information relating to the registrant, including its consolidated subsidiaries, is made known to us by others within those entities, particularly during the period in which this report is being prepared;
 - b) Designed such internal control over financial reporting, or caused such internal control over financial reporting to be designed under our supervision, to provide reasonable assurance regarding the reliability of financial reporting and the preparation of financial statements for external purposes in accordance with generally accepted accounting principles;
 - c) Evaluated the effectiveness of the registrant's disclosure controls and procedures and presented in this report our conclusions about the effectiveness of the disclosure controls and procedures, as of the end of the period covered by this report based on such evaluation; and
 - d) Disclosed in this report any change in the registrant's internal control over financial reporting that occurred during the registrant's most recent fiscal quarter (the registrant's fourth fiscal quarter in the case of an annual report) that has materially affected, or is reasonably likely to materially affect, the registrant's internal control over financial reporting; and
5. The registrant's other certifying officer and I have disclosed, based on our most recent evaluation of internal control over financial reporting, to the registrant's auditors and the audit committee of the registrant's board of directors (or persons performing the equivalent functions):
 - a) All significant deficiencies and material weaknesses in the design or operation of internal control over financial reporting which are reasonably likely to adversely affect the registrant's ability to record, process, summarize and report financial information; and
 - b) Any fraud, whether or not material, that involves management or other employees who have a significant role in the registrant's internal control over financial reporting.

/s/ Carlos M. Cardoso
Carlos M. Cardoso
Chairman, President and Chief Executive Officer
August 14, 2009

I, Frank P. Simpkins, certify that:

1. I have reviewed this annual report on Form 10-K of Kennametal Inc.;
2. Based on my knowledge, this report does not contain any untrue statement of a material fact or omit to state a material fact necessary to make the statements made, in light of the circumstances under which such statements were made, not misleading with respect to the period covered by this report;
3. Based on my knowledge, the financial statements, and other financial information included in this report, fairly present in all material respects the financial condition, results of operations and cash flows of the registrant as of, and for, the periods presented in this report;
4. The registrant's other certifying officer and I are responsible for establishing and maintaining disclosure controls and procedures (as defined in Exchange Act Rules 13a-15(e) and 15d-15(e)) and internal control over financial reporting (as defined in Exchange Act Rules 13a-15(f) and 15d-15(f)) for the registrant and have:
 - a) Designed such disclosure controls and procedures, or caused such disclosure controls and procedures to be designed under our supervision, to ensure that material information relating to the registrant, including its consolidated subsidiaries, is made known to us by others within those entities, particularly during the period in which this report is being prepared;
 - b) Designed such internal control over financial reporting, or caused such internal control over financial reporting to be designed under our supervision, to provide reasonable assurance regarding the reliability of financial reporting and the preparation of financial statements for external purposes in accordance with generally accepted accounting principles;
 - c) Evaluated the effectiveness of the registrant's disclosure controls and procedures and presented in this report our conclusions about the effectiveness of the disclosure controls and procedures, as of the end of the period covered by this report based on such evaluation; and
 - d) Disclosed in this report any change in the registrant's internal control over financial reporting that occurred during the registrant's most recent fiscal quarter (the registrant's fourth fiscal quarter in the case of an annual report) that has materially affected, or is reasonably likely to materially affect, the registrant's internal control over financial reporting; and
5. The registrant's other certifying officer and I have disclosed, based on our most recent evaluation of internal control over financial reporting, to the registrant's auditors and the audit committee of the registrant's board of directors (or persons performing the equivalent functions):
 - a) All significant deficiencies and material weaknesses in the design or operation of internal control over financial reporting which are reasonably likely to adversely affect the registrant's ability to record, process, summarize and report financial information; and
 - b) Any fraud, whether or not material, that involves management or other employees who have a significant role in the registrant's internal control over financial reporting.

/s/ Frank P. Simpkins
Frank P. Simpkins
Vice President and Chief Financial Officer
August 14, 2009

**CERTIFICATION PURSUANT TO 18 U.S.C. SECTION 1350, AS ADOPTED PURSUANT TO SECTION 906 OF THE
SARBANES-OXLEY ACT OF 2002**

In connection with the Annual Report of Kennametal Inc. (the "Corporation") on Form 10-K for the period ended June 30, 2009, as filed with the Securities and Exchange Commission on the date hereof (the "Report"), each of the undersigned officers of the Corporation certifies, pursuant to 18 U.S.C. Section 1350, as adopted pursuant to Section 906 of the Sarbanes-Oxley Act of 2002, that, to his knowledge:

- (1) The Report fully complies with the requirements of Section 13(a) or 15(d) of the Securities Exchange Act of 1934; and
- (2) The information contained in the Report fairly presents, in all material respects, the financial condition and result of operations of the Corporation.

/s/ Carlos M. Cardoso

Carlos M. Cardoso
Chairman, President and Chief Executive Officer
August 14, 2009

/s/ Frank P. Simpkins

Frank P. Simpkins
Vice President and Chief Financial Officer
August 14, 2009

*This certification is made solely for purposes of 18 U.S.C. Section 1350, subject to the knowledge standard contained therein, and not for any other purpose.

2009 SUPPLEMENTAL FINANCIAL DATA

2009 SUPPLEMENTAL FINANCIAL DATA (UNAUDITED)

The following 2009 Supplemental Financial Data is not part of our Form 10-K.

The following financial schedules provide a reconciliation of reported results under generally accepted accounting principles in the United States of America (GAAP) to those non-GAAP financial measures included in our Annual Report to Shareowners. Management believes that the investor should have available the same information that management uses to assess operating performance, determine compensation, and assess the capital structure of the Company. These non-GAAP measures should not be considered in isolation or as a substitute for the most comparable GAAP measures. Investors are cautioned that non-GAAP financial measures utilized by the Company may not be comparable to non-GAAP financial measures used by other companies.

Adjusted EBIT

EBIT is an acronym for Earnings Before Interest and Taxes and is a non-GAAP financial measure. The most directly comparable GAAP measure is net income. However, we believe that EBIT is widely used as a measure of operating performance and we believe EBIT to be an important indicator of the Company's operational strength and performance. Nevertheless, the measure should not be considered in isolation or as a substitute for operating income, cash flows from operating activities or any other measure for determining liquidity that is calculated in accordance with GAAP. Additionally, Kennametal will adjust EBIT for minority interest expense, interest income, securitization fees, pre-tax income from discontinued operations and special items. Management uses this information in reviewing operating performance and in determining compensation.

Adjusted Operating Income, Adjusted Net Income, Adjusted Diluted Earnings per Share and Adjusted Effective Tax Rate

The following GAAP financial measures have been presented excluding special items: operating income, net income, diluted earnings per share (EPS) and effective tax rate (ETR). Detail of these special items is included in the reconciliations following these definitions. Management excludes these items in measuring and compensating internal performance to more easily compare the Company's financial performance period-to-period.

Adjusted Operating Cash Flow and Adjusted Free Operating Cash Flow

Adjusted operating cash flow is a non-GAAP financial measure and is defined by the Company as cash provided by operations (in accordance with GAAP) plus or minus one-time unusual cash items. Adjusted free operating cash flow (FOCF) is a non-GAAP financial measure and is defined by the Company as cash provided by operations (in accordance with GAAP) less capital expenditures, plus proceeds from disposals of fixed assets and plus or minus other one-time unusual cash items. Management considers these measures to be an important indicator of Kennametal's cash generating capability because they better represent cash generated from operations that can be used for strategic initiatives (such as acquisitions), dividends, debt repayment and other investing and financing activities.

Adjusted Return on Invested Capital

Adjusted Return on Invested Capital (ROIC) is a non-GAAP financial measure and is defined by the Company as the previous twelve months' net income, adjusted for interest expense, securitization fees, minority interest expense and special items, divided by the sum of the previous 5 quarters' average balances of debt, securitized accounts receivable, minority interest and shareowners' equity. Management believes that this financial measure provides additional insight into the underlying capital structure and performance of the Company. Management utilizes this non-GAAP measure in determining compensation and assessing the operations of the Company. The most directly comparable GAAP measure is return on invested capital calculated utilizing GAAP net income.

Primary Working Capital

Primary Working Capital (PWC) is a non-GAAP financial measure and is defined as accounts receivable, net plus inventories, net minus accounts payable. The most directly comparable GAAP measure is working capital, which is defined as current assets less current liabilities. We believe primary working capital better represents the Company's performance in managing certain assets and liabilities controllable at the business unit level and it is used as such for internal performance measurement.

RECONILIATIONS (UNAUDITED)

ADJUSTED EBIT (Unaudited)

Year ended June 30 (in thousands, except percents)	2009	2008	2007	2006	2005
Net (loss) income, as reported	\$ (119,742)	\$ 167,775	\$ 174,243	\$ 256,283	\$ 119,291
Net (loss) income as a percent of sales	(6.0%)	6.5%	7.7%	11.6%	5.7%
Add back:					
Interest expense	27,244	31,586	28,999	30,941	27,236
Interest expense reported in discontinued operations	81	142	142	78	41
Tax (benefit) expense	(11,205)	62,754	68,251	170,369	57,705
Tax expense (benefit) on discontinued operations	(8,583)	1,303	2,353	(17,210)	3,689
EBIT	(112,205)	263,560	273,988	440,461	207,962
Additional adjustments:					
Minority interest expense	1,111	2,980	2,185	2,566	3,592
Interest income	(4,779)	(5,082)	(5,676)	(4,838)	(3,462)
Securitization fees	-	22	38	4,764	3,186
Pre-interest pre-tax income from discontinued operations	(355)	(5,554)	(5,663)	(9,975)	(15,053)
Special Items:					
Loss on HSS divestiture and transaction-related charges	26,197	-	-	-	-
Asset impairment charges	111,042	35,000	-	-	-
Restructuring and related charges	73,292	8,248	-	-	-
Loss on Electronics divestiture, impairment and transaction-related charges	-	-	3,072	21,965	-
Loss on sale of CPG, impairment and transaction-related charges	-	-	570	16,511	-
Gain on J&L divestiture and transaction-related charges	-	-	2,019	(227,568)	-
Loss on Presto divestiture	-	-	-	9,457	-
Loss on FSS divestiture and goodwill impairment charge	-	-	-	-	6,253
Adjusted EBIT	\$ 94,303	\$ 299,174	\$ 270,533	\$ 253,343	\$ 202,478
Adjusted EBIT as a percent of sales	4.7%	11.6%	11.9%	11.4%	9.7%

YEAR ENDED JUNE 30, 2009 (UNAUDITED)

(in thousands, except percents and per share amounts)	Effective Tax Rate	Operating Loss	Net Loss	Diluted LPS
Reported Results	10.0%	\$ (99,818)	\$ (119,742)	\$ (1.64)
Restructuring and related charges	(1.5)	73,292	60,020	0.82
Asset impairment charges	8.1	111,042	101,200	1.38
Loss on HSS divestiture and transaction-related charges	-	-	17,657	0.24
Adjusted Results	16.6%	\$ 84,516	\$ 59,135	\$ 0.80

YEAR ENDED JUNE 30, 2008 (UNAUDITED)

(in thousands, except percents and per share amounts)	Effective Tax Rate	Operating Income	Net Income	Diluted EPS
Reported Results	27.4%	\$ 258,547	\$ 167,775	\$ 2.15
German tax law change	(2.4)	-	6,594	0.08
Goodwill impairment charge	(3.6)	35,000	35,000	0.45
Restructuring and related charges	(0.2)	8,248	6,635	0.08
Adjusted Results	21.2%	\$ 301,795	\$ 216,004	\$ 2.76

YEAR ENDED JUNE 30, 2007 (UNAUDITED)

(in thousands, except percents and per share amounts)	Effective Tax Rate	Operating Income	Net Income	Diluted EPS
Reported Results	27.8%	\$ 265,739	\$ 174,243	\$ 2.22
Electronics impairment and transaction-related charges	-	-	3,213	0.04
Adjustment on J&L divestiture and transaction-related charges	0.1	2,019	1,252	0.02
Adjusted Results	27.9%	\$ 267,758	\$ 178,708	\$ 2.28

YEAR ENDED JUNE 30, 2006 (UNAUDITED) (in thousands, except percents and per share amounts)	Effective Tax Rate	Operating Income	Net Income	Diluted EPS
Reported Results	38.7%	\$ 468,611	\$ 256,283	\$ 3.24
Gain on J&L divestiture and transaction-related charges	(6.4)	(227,568)	(128,045)	(1.62)
Loss on divestiture of Electronics	-	-	15,366	0.19
CPG goodwill impairment and transaction-related charges	-	-	2,838	0.04
Tax impact of cash repatriation under AJCA	(0.7)	-	11,176	0.14
Loss on Presto divestiture	(0.6)	9,457	9,457	0.12
Favorable resolution of tax contingencies	0.7	-	(10,873)	(0.14)
Adjusted Results	31.7%	\$ 250,500	\$ 156,202	\$ 1.97

YEAR ENDED JUNE 30, 2005 (UNAUDITED) (in thousands, except percents and per share amounts)	Effective Tax Rate	Operating Income	Net Income	Diluted EPS
Reported Results	34.1%	\$ 192,865	\$ 119,291	\$ 1.57
Loss on FSS divestiture and goodwill impairment charge	(0.1)	6,253	4,353	0.05
Adjusted Results	34.0%	\$ 199,118	\$ 123,644	\$ 1.62

ADJUSTED OPERATING CASH FLOW AND

ADJUSTED FOCF (UNAUDITED) (in thousands, except percents)	2009	2008	2007	2006	2005
Net cash flow provided by operating activities	\$ 192,263	\$ 279,786	\$ 199,006	\$ 19,053	\$ 202,327
Adjustments:					
Repayments of accounts receivable securitization program	-	-	-	109,786	-
Pension funding	-	-	-	72,956	-
Income taxes paid during first quarter 2007	-	-	86,236	-	-
Adjusted operating cash flow	\$ 192,263	\$ 279,786	\$ 285,242	\$ 201,795	\$ 202,327
Adjusted operating cash flow, as a percent of sales	9.6%	10.8%	12.6%	9.1%	9.7%
Purchases of property, plant and equipment	(104,842)	(163,489)	(92,001)	(79,593)	(88,552)
Proceeds from disposals of property, plant and equipment	2,914	2,839	3,455	2,961	3,912
Repayments of accounts receivable securitization program	-	-	-	-	7,694
Adjusted free operating cash flow	\$ 90,335	\$ 119,136	\$ 196,696	\$ 125,163	\$ 125,381

RETURN ON INVESTED CAPITAL (UNAUDITED)

June 30, 2009 (in thousands, except percents)

Invested Capital	6/30/2009	3/31/2009	12/31/2008	9/30/2008	6/30/2008	Average
Debt	\$ 485,957	\$ 502,093	\$ 522,722	\$ 481,723	\$ 346,652	\$ 467,829
Minority interest	20,012	18,678	19,235	20,412	21,527	19,973
Shareowners' equity	1,247,443	1,249,328	1,430,727	1,465,757	1,647,907	1,408,232
Total	\$ 1,753,412	\$ 1,770,099	\$ 1,972,684	\$ 1,967,892	\$ 2,016,086	\$ 1,896,035

	Three Months Ended				Total
Interest Expense	6/30/2009	3/31/2009	12/31/2008	9/30/2008	
Interest expense	\$ 5,503	\$ 6,658	\$ 8,000	\$ 7,083	\$ 27,244
Income tax benefit					4,523
Total interest expense, net of tax					<u>\$ 22,721</u>

Total Income	6/30/2009	3/31/2009	12/31/2008	9/30/2008	Total
Net income, as reported	\$ (32,993)	\$ (137,875)	\$ 15,659	\$ 35,467	\$ (119,742)
Restructuring and related charges	6,065	36,768	9,779	7,408	60,020
Asset impairment charges	-	101,200	-	-	101,200
Loss on HSS divestiture and transaction-related charges	17,258	399	-	-	17,657
Minority interest expense	266	161	(101)	785	1,111
Total income, adjusted	\$ (9,404)	\$ 653	\$ 25,337	\$ 43,660	\$ 60,246

Total interest expense, net of tax					<u>22,721</u>
					\$ 82,967

Average invested capital \$ 1,896,035**Adjusted Return on Invested Capital** **4.4%****Return on invested capital calculated utilizing net income, as reported is as follows:**

Net income, as reported	\$ (119,742)
Total interest expense, net of tax	22,721
	<u>\$ (97,021)</u>
Average invested capital	\$ 1,896,035
Return on Invested Capital	<u>(5.1%)</u>

RETURN ON INVESTED CAPITAL (UNAUDITED)

June 30, 2008 (in thousands, except percents)

Invested Capital	6/30/2008	3/31/2008	12/31/2007	9/30/2007	6/30/2007	Average
Debt	\$ 346,652	\$ 428,456	\$ 446,956	\$ 377,051	\$ 366,829	\$ 393,189
Minority interest	21,527	21,879	20,276	19,122	17,624	20,086
Shareowners' equity	1,647,907	1,615,568	1,563,297	1,531,378	1,484,467	1,568,523
Total	\$ 2,016,086	\$ 2,065,903	\$ 2,030,529	\$ 1,927,551	\$ 1,868,920	\$ 1,981,798

	Three Months Ended				Total
Interest Expense	6/30/2008	3/31/2008	12/31/2007	9/30/2007	
Interest expense	\$ 7,351	\$ 7,974	\$ 8,494	\$ 7,767	\$ 31,586
Securitization fees	4	5	5	8	22
Total interest expense	\$ 7,355	\$ 7,979	\$ 8,499	\$ 7,775	\$ 31,608
Income tax benefit					6,701
Total interest expense, net of tax					\$ 24,907
Total Income	6/30/2008	3/31/2008	12/31/2007	9/30/2007	Total
Net income, as reported	\$ 59,580	\$ 23,170	\$ 50,146	\$ 34,879	\$ 167,775
Impact of German tax reform bill	-	-	-	6,594	6,594
Goodwill impairment charge	-	35,000	-	-	35,000
Restructuring and related charges	6,635	-	-	-	6,635
Minority interest expense	329	742	1,037	872	2,980
Total income, adjusted	\$ 66,544	\$ 58,912	\$ 51,183	\$ 42,345	\$ 218,984
Total interest expense, net of tax					24,907
					\$ 243,891
Average invested capital					\$ 1,981,798
Adjusted Return on Invested Capital					12.3%

Return on invested capital calculated utilizing net income, as reported is as follows:

Net income, as reported	\$ 167,775
Total interest expense, net of tax	24,907
	\$ 192,682
Average invested capital	\$ 1,981,798
Return on Invested Capital	9.7%

RETURN ON INVESTED CAPITAL (UNAUDITED)

June 30, 2007 (in thousands, except percents)

Invested Capital	6/30/2007	3/31/2007	12/31/2006	9/30/2006	6/30/2006	Average
Debt	\$ 366,829	\$ 371,521	\$ 376,472	\$ 409,592	\$ 411,722	\$ 387,227
Minority interest	17,624	16,896	15,807	15,177	14,626	16,026
Shareowners' equity	1,484,467	1,431,235	1,369,748	1,319,599	1,295,365	1,380,083
Total	\$ 1,868,920	\$ 1,819,652	\$ 1,762,027	\$ 1,744,368	\$ 1,721,713	\$ 1,783,336

	Three Months Ended				
Interest Expense	6/30/2007	3/31/2007	12/31/2006	9/30/2006	Total
Interest expense	\$ 7,474	\$ 6,867	\$ 7,248	\$ 7,410	\$ 28,999
Securitization fees	5	5	6	22	38
Total interest expense	\$ 7,479	\$ 6,872	\$ 7,254	\$ 7,432	\$ 29,037
Income tax benefit					8,101
Total interest expense, net of tax					\$ 20,936

Total Income	6/30/2007	3/31/2007	12/31/2006	9/30/2006	Total
Net income, as reported	\$ 62,093	\$ 51,738	\$ 30,051	\$ 30,361	\$ 174,243
Adjustment on J&L divestiture and transaction-related charges	-	-	-	1,252	1,252
Electronics impairment and transaction-related charges	-	-	3,213	-	3,213
Loss on CPG divestiture and transaction-related charges	-	-	-	368	368
Minority interest expense	229	757	642	557	2,185
Total income, adjusted	\$ 62,322	\$ 52,495	\$ 33,906	\$ 32,538	\$ 181,261

Total interest expense, net of tax	20,936
	\$ 202,197
Average invested capital	\$ 1,783,336

Adjusted Return on Invested Capital **11.3%****Return on invested capital calculated utilizing net income, as reported is as follows:**

Net income, as reported	\$ 174,243
Total interest expense, net of tax	20,936

	\$ 195,179
Average invested capital	\$ 1,783,336

Return on Invested Capital **10.9%**

RETURN ON INVESTED CAPITAL (UNAUDITED)

June 30, 2006 (in thousands, except percents)

Invested Capital	6/30/2006	3/31/2006	12/31/2005	9/30/2005	6/30/2005	Average
Debt	\$ 411,722	\$ 365,906	\$ 410,045	\$ 415,250	\$ 437,374	\$ 408,060
Accounts receivable securitized	-	106,106	100,295	100,445	109,786	83,326
Minority interest	14,626	18,054	16,918	18,117	17,460	17,035
Shareowners' equity	1,295,365	1,115,110	1,045,974	1,009,394	972,862	1,087,741
Total	\$ 1,721,713	\$ 1,605,176	\$ 1,573,232	\$ 1,543,206	\$ 1,537,482	\$ 1,596,162

Interest Expense	Three Months Ended				Total
	6/30/2006	3/31/2006	12/31/2005	9/30/2005	
Interest expense	\$ 7,460	\$ 7,708	\$ 7,964	\$ 7,809	\$ 30,941
Securitization fees	1,288	1,241	1,170	1,065	4,764
Total interest expense	\$ 8,748	\$ 8,949	\$ 9,134	\$ 8,874	\$ 35,705
Income tax benefit					11,318
Total interest expense, net of tax					\$ 24,387

Total Income	6/30/2006	3/31/2006	12/31/2005	9/30/2005	Total
Net income, as reported	\$ 164,196	\$ 32,903	\$ 31,087	\$ 28,097	\$ 256,283
Gain on J&L divestiture and transaction-related charges	(129,205)	1,160	-	-	(128,045)
Loss on Electronics divestiture	15,366	-	-	-	15,366
Tax impact of cash repatriation under AJCA	11,176	-	-	-	11,176
CPG goodwill impairment and transaction-related charges	(2,192)	5,030	-	-	2,838
Loss on Presto divestiture	1,410	8,047	-	-	9,457
Favorable resolution of tax contingencies	(10,873)	-	-	-	(10,873)
Minority interest expense	525	782	511	748	2,566
Total income, adjusted	\$ 50,403	\$ 47,922	\$ 31,598	\$ 28,845	\$ 158,768
Total interest expense, net of tax					24,387

Average invested capital

\$ 183,155

\$ 1,596,162

Adjusted Return on Invested Capital**11.5%****Return on invested capital calculated utilizing net income, as reported is as follows:**

Net income, as reported	\$ 256,283
Total interest expense, net of tax	24,387
	\$ 280,670
Average invested capital	\$ 1,596,162
Return on Invested Capital	17.6%

RETURN ON INVESTED CAPITAL (UNAUDITED)

June 30, 2005 (in thousands, except percents)

Invested Capital	6/30/2005	3/31/2005	12/31/2004	9/30/2004	6/30/2004	Average
Debt	\$ 437,374	\$ 485,168	\$ 405,156	\$ 435,435	\$ 440,207	\$ 440,668
Accounts receivable securitized	109,786	120,749	115,253	115,309	117,480	115,715
Minority interest	17,460	19,664	19,249	17,377	16,232	17,996
Shareowners' equity	972,862	1,021,186	1,003,507	924,432	887,152	961,828
Total	\$ 1,537,482	\$ 1,646,767	\$ 1,543,165	\$ 1,492,553	\$ 1,461,071	\$ 1,536,207

	Three Months Ended				Total
Interest Expense	6/30/2005	3/31/2005	12/31/2004	9/30/2004	
Interest expense	\$ 7,886	\$ 6,793	\$ 6,111	\$ 6,446	\$ 27,236
Securitization fees	981	868	757	580	3,186
Total interest expense	\$ 8,867	\$ 7,661	\$ 6,868	\$ 7,026	\$ 30,422
Income tax benefit					10,343
Total interest expense, net of tax					\$ 20,079

Total Income	6/30/2005	3/31/2005	12/31/2004	9/30/2004	Total
Net income, as reported	\$ 37,740	\$ 30,650	\$ 28,181	\$ 22,720	\$ 119,291
Restructuring and asset impairment charges	-	3,306	-	-	3,306
Loss on assets held for sale	-	1,086	-	-	1,086
Minority interest expense	238	1,449	928	977	3,592
Total income, adjusted	\$ 37,978	\$ 36,491	\$ 29,109	\$ 23,697	\$ 127,275
Total interest expense, net of tax					20,079

	\$ 147,354
Average invested capital	\$ 1,536,207

Adjusted Return on Invested Capital**9.6%****Return on invested capital calculated utilizing net income, as reported is as follows:**

Net income, as reported	\$ 119,291
Total interest expense, net of tax	20,079
	\$ 139,370
Average invested capital	\$ 1,536,207
Return on Invested Capital	9.1%

PRIMARY WORKING CAPITAL RECONCILIATION (UNAUDITED)

June 30, (in thousands, except percents)	2009	2008	2007	2006	2005
Current assets	\$ 875,904	\$ 1,151,986	\$ 1,016,502	\$ 1,086,857	\$ 831,062
Current liabilities	378,969	521,311	487,237	462,199	428,658
Working capital in accordance with GAAP	\$ 496,935	\$ 630,675	\$ 529,265	\$ 624,658	\$ 402,404
Excluding items:					
Cash and cash equivalents	(69,823)	(86,478)	(50,433)	(233,976)	(43,220)
Other current assets	(145,798)	(91,914)	(95,766)	(131,218)	(107,857)
Total excluded current assets	(215,621)	(178,392)	(146,199)	(365,194)	(151,077)
Adjusted current assets	660,283	973,594	870,303	721,663	679,985
Current maturities of long-term debt and capital leases, including notes payable	(49,365)	(33,600)	(5,430)	(2,214)	(50,889)
Other current liabilities	(242,428)	(298,661)	(292,506)	(335,078)	(222,930)
Total excluded current liabilities	(291,793)	(332,261)	(297,936)	(337,292)	(273,819)
Adjusted current liabilities	87,176	189,050	189,301	124,907	154,839
Primary working capital	\$ 573,107	\$ 784,544	\$ 681,002	\$ 596,756	\$ 525,146
Primary working capital, as a percent of sales	28.7%	30.3%	30.1%	27.0%	25.1%

BOARD OF DIRECTORS

Carlos M. Cardoso
Chairman of the Board, President and Chief Executive Officer
 Kennametal

Ronald M. DeFeo
Chairman and Chief Executive Officer
 Terex Corporation

Philip A. Dur
Former Corporate Vice President and President Ship Systems Sector
 Northrop Grumman Corporation

A. Peter Held
Former President
 Cooper Tools Division
 Cooper Industries

Timothy R. McLevish
Executive Vice President and Chief Financial Officer
 Kraft Foods, Inc.

William R. Newlin
Chairman
 Newlin Investment Company LLC

Lawrence W. Stranghoener
Executive Vice President and Chief Financial Officer
 The Mosaic Company

Steven H. Wunning
Group President and Executive Office Member
 Caterpillar Inc.

Larry D. Yost
Lead Director
 Kennametal
Former Chairman and Chief Executive Officer
 ArvinMeritor, Inc.

CORPORATE INFORMATION

World and North America

Headquarters
 Kennametal Inc.
 1600 Technology Way
 P.O. Box 231
 Latrobe, Pennsylvania 15650-0231
 U.S.A.
 (01) 724-539-5000 Tel
 (01) 724-539-4710 Fax
 www.kennametal.com

Europe Headquarters

Kennametal Europe GmbH
 Rheingoldstrasse 50
 CH 8212 Neuhausen am Rheinfall
 Switzerland
 (41) 52-6750-100 Tel
 (41) 52-6750-101 Fax

Asia Pacific Headquarters

Kennametal Singapore Pte. Ltd
 No. 11 Gul Link Jurong
 Singapore 629381
 (65) 6 2659222 Tel
 (65) 6 8610922 Fax

Transfer Agent, Registrar of Stock and Dividend Disbursing Agent

BNY Mellon Shareowner Services
 480 Washington Boulevard
 Jersey City, New Jersey 07310-1900
 U.S.A.
 (01) 866-211-6288 Tel
 www.bnymellon.com/shareowner/isd

Stock Listing

The New York Stock Exchange
 Ticker Symbol: KMT
 CUSIP No.: 489170100



Independent Registered Public Accounting Firm
 PricewaterhouseCoopers LLP

Investor Relations and Media Information

Securities analysts, shareowners and others seeking financial information should call Ms. Quynh McGuire, Director of Investor Relations, at (01) 724-539-6559. News media and others seeking general information should contact Ms. Joy Chandler, Vice President of Corporate Relations, at (01) 724-539-4618.

Dividend Reinvestment and Stock Purchase Plan

This plan provides shareowners with a convenient way to acquire additional shares of Kennametal stock without paying brokerage fees or service charges. Participants may reinvest their dividends, plus optional cash if desired, to acquire these additional shares. BNY Mellon Shareowner Services administers the plan and acts as the agent for the participants. For more information, contact BNY Mellon at (01) 866-211-6288.

Equal Opportunity Employer

Kennametal is an equal opportunity employer. All matters regarding recruiting, hiring, training, compensation, benefits, promotions, transfers and all other personnel policies will continue to be free from discriminatory practices.

Annual Meeting

The Annual Meeting of Shareowners will be held at the Quentin C. McKenna Technology Center, located at 1600 Technology Way, Latrobe, Pennsylvania, U.S.A. on Tuesday, October 27, 2009. Notice of the meeting will be mailed on or about Thursday, September 10, 2009, to shareowners of record at the close of business on Wednesday, August 26, 2009. All shareowners are cordially invited to attend. Proxies will be solicited by the Board of Directors.



Kennametal employees continued their commitment to *Protecting Our Planet* in fiscal 2009. Recognizing that resource conservation is key to our competitiveness and sustainability, the team made significant strides in energy and water conservation, materials recycling, waste reduction and other practices consistent with our tradition of responsible environmental stewardship. The company's top performing teams were honored at a global ceremony celebrating Kennametal's ongoing dedication to *Protecting Our Planet*.